

MONTAGE HANDLEIDING
MONTAGEANVISNING
MOUNTING INSTRUCTION
MONTAGE ANWEISUNG

Takzip TZ330



www.styrasolskydd.se



NEDERLANDS

Algemene informatie

Beste klant, dank u voor uw keuze van een HAROL overkapping van de serie VZ. Onze onderneming heeft ervoor gekozen om te investeren in kwaliteit en innovatie, door zowel de materialen als de productieprocessen te selecteren en te perfectioneren.

OPGELET: Leest u, voordat u de zonwering gebruikt, aandachtig alle waarschuwingen en instructies in deze handleiding en in de handleiding met gebruiksinstructies voor. Deze handleidingen zijn onderdeel van het product en moeten voor toekomstig gebruik bewaard en altijd ter beschikking worden gehouden, zolang de zonwering niet wordt afgedankt.

Opmerkingen

De installatie moet worden uitgevoerd door gekwalificeerd personeel in overeenstemming met de IEC-normen en de nationale bepalingen inzake civiele elektrische installaties.

Raadpleeg ook de technische fiche

! Lees deze handleiding vooraf zorgvuldig door.

! Door het opspannen van de veren ontstaan er grote krachten. Ga voorzichtig te werk. Zorg dat u stevig staat.

! Zorg voor een montageruimte met voldoende licht. Verwijder obstakels en vuil. Zorg ervoor dat er geen andere personen dan monteurs aanwezig zijn. Onbevoegden kunnen in de weg lopen of gevaar lopen tijdens de montage.



Dit symbool duidt op mogelijk gevaar voor personen of schade aan het product.



Dit symbool geeft "Opgelet" aan.



Dit symbool geeft het gebruik van kracht aan om de aangegeven werkzaamheid te verrichten.

Wanneer u elektrische schroevendraaiers gebruikt, stelt u dan de juiste koppelwaarde in.



Dit symbool geeft aan dat er een visuele controle dient uitgevoerd te worden



Dit symbool geeft een optioneel toebehoren aan.

De fabrikant is niet aansprakelijk voor eventuele onjuistheden te wijten aan druk- fouten die in deze handleiding kunnen aanwezig zijn. Hij behoudt zich het recht voor om nodige of voor de gebruiker nuttige wijzigingen aan zijn producten door te voeren, zonder afbreuk te doen aan de functionaliteit en de veiligheid.

Geen aanpassingen aan design en configuratie zonder consultatie van fabrikant.

De gebruikershandleiding moet overhandigd worden aan de eindgebruiker.



ENGLISH

General Information

Dear Customer, thanks for having chosen a HAROL cover of VZ line. Our company has been designing and producing sun awnings since 1960. since our very beginning we have chosen to invest on quality and innovation, selecting and improving both the materials used and the productive processes.

WARNING: before using the awning, read carefully this instructions manual and also the one called "Instructions Manual". This manuals are part of the product and must be properly stored for any future need until the awning disposal.

Warnings

Installation must be carried out by qualified personnel in compliance with EN and local safety regulations relative to domestic electrical systems.

See also product technical data document.

! Before you start ,please do read these instructions thoroughly.

! The tightening of springs creates important powers. Be very careful and make sure of a solid footing whilst operating.!

Provide sufficient light in the fitting area. Dispose of obstacles and dirt. Make sure that, except for the fitters, no other people are in the fitting area. Unauthorized people might be in the way or at risk themselves.



This symbol indicates the possibility of injury to persons or damage to the product.



This symbol means "Warning".



This symbol means to use force during the shown operation.

Using electric screwdrivers set the correct torque value.



This symbol means the need of a visual control.



This symbol indicate a particular which is given as optional.

The manufacturer accepts no liability for any inaccuracies or printing errors that may be contained in this manual. The manufacturer reserves the right to introduce any modifications to the product that are considered necessary or in the interests of the user and which do not alter the essential operational and safety characteristics of the appliance.

No modification of the design or configuration without consulting the manufacturer.

The instruction of use shall be provided to the end user.



FRANÇAIS

Informations Générales

Cher Client, merci d'avoir choisi une structure HAROL de la série VZ. Notre société conçoit et produit des stores pare-soleil depuis 1960 ; dès le départ, nous avons choisi d'investir sur la qualité et sur l'innovation, en sélectionnant et en perfectionnant tant les matériaux que les processus de fabrication.

ATTENTION : avant d'utiliser le store, lire attentivement tous les avertissements et les instructions figurant dans ce manuel et dans le manuel "Manuel d'utilisation." Ces manuels font partie intégrante du produit et ils doivent être conservés et être toujours à disposition pour toutes consultations futures, jusqu'à l'élimination du store.

Avertissements

L'installation doit être effectuée par du personnel qualifié conformément aux normes NF et aux dispositions nationales relatives aux installations électriques civiles.

Voir aussi la fiche technique

! Commencez par lire attentivement cette notice!

! La tension des ressorts crée une force importante. Procédez avec précaution. Positionnez-vous de manière stable.

! Veillez à ce que le lieu de montage soit suffisamment éclairé. Débarrassez-vous des obstacles et des crasses. Assurez-vous qu'il n'y a personne d'autre que les monteurs. Des personnes incompétentes pourraient vous gêner ou courir un danger pendant le montage.



Ce symbole indique un risque de danger pour les personnes ou de dommage à le produit.



Ce symbole indique: «Attention».



Ce symbole vous indique d'utiliser de la force au cours de l'opération.

Si on utilise un visseuse électrique il faut définir la valeur de couple correcte pour le serrage.



Ce symbole vous indique qu'il faut effectuer un contrôle visuel.



Ce symbole vous indique un accessoire en option.

Le Fabricant décline toute responsabilité pour les éventuelles inexactitudes imputables à des erreurs d'impression ou de transcription contenues dans cette notice. Il se réserve la faculté d'apporter à ses produits toutes les modifications qu'il estime nécessaires au utiles, y compris dans l'intérêt des utilisateurs, sans modifier leurs caractéristiques essentielles de fonctionnalité et sécurité.

Aucune modification de conception ou de configuration sans consultation du fabricant.

L'instruction d'utilisation doit être fournie à l'utilisateur final.



DEUTSCH

Allgemeine Hinweise

Sehr geehrter Kunde, vielen Dank für die Wahl eine HAROL Abdeckung der Serie VZ. Unsere Firma entwirft und produziert Markisen seit 1960; vom Anfang an haben wir gewählt in Qualität und Innovation zu investieren, indem die Materialien wie auch die Produktionsvorgänge ausgewählt und verbessert wurden.

ACHTUNG: vor der Markisenbenutzung bitte alle Hinweise und Anleitungen in diesem Handbuch und im Handbuch "Bedienungsanleitung" sorgfältig lesen. Diese Handbücher begleiten das Produkt und müssen sorgfältig aufbewahrt werden um für jede weitere Information griffbereit zu bleiben, bis die Markise entsorgt wird.

Anmerkung

Die Installation ist von Fachpersonal und unter Beachtung der IECBestimmungen und der örtlichen Vorschriften bezüglich elektrischer Anlagen auszuführen.

Siehe auch die Technische Angaben.

! Lesen Sie die Anleitung vor der Montage sorgfältig durch!

! Durch das Spannen der Federn entstehen grosse Kräfte. Gehen Sie bitte vorsichtig vor und sorgen Sie dafür, dass Sie einen festen Stand haben!

! Sorgen Sie für ausreichend Licht auf der Montagefläche. Entfernen Sie Hindernisse und Abfall.



Dieses Symbol weist auf eine mögliche Gefahr für Personen bzw. Schäden am Produkt.



Dieses Symbol steht für "Vorsicht!"



Dieses Symbol bedeutet, Kräfteanwendung bei der Operationsdurchführung.

Wenn Sie Elektrische Schrauben benutzen, achten Sie bitte auf den korrekte Drehmoment.



Dieses Symbol bedeutet, dass ein visuell Steuerung angewendet werden muss.



Dieses Symbol kennzeichnet ein optionales Zubehör.

Für Unrichtigkeiten in diesem Handbuch, die auf Druck- oder Abschreibefehler zurückzuführen sind, übernimmt der Hersteller keine Haftung. Der Hersteller behält sich das Recht vor, alle für notwendig erachteten bzw. im Interesse der Abnehmer liegenden Änderungen an seinen Produkten vorzunehmen, ohne jedoch deren wesentliche Funktions- und Sicherheitsigenschaften zu beeinträchtigen.

Keine Änderung der Gestaltung oder Konfiguration der Ausrüstung ohne Rücksprache mit dem Hersteller.

Die Gebrauchsanleitung für den Endnutzer bereitzustellen ist.

MONTAGE - MOUNTING TZ330

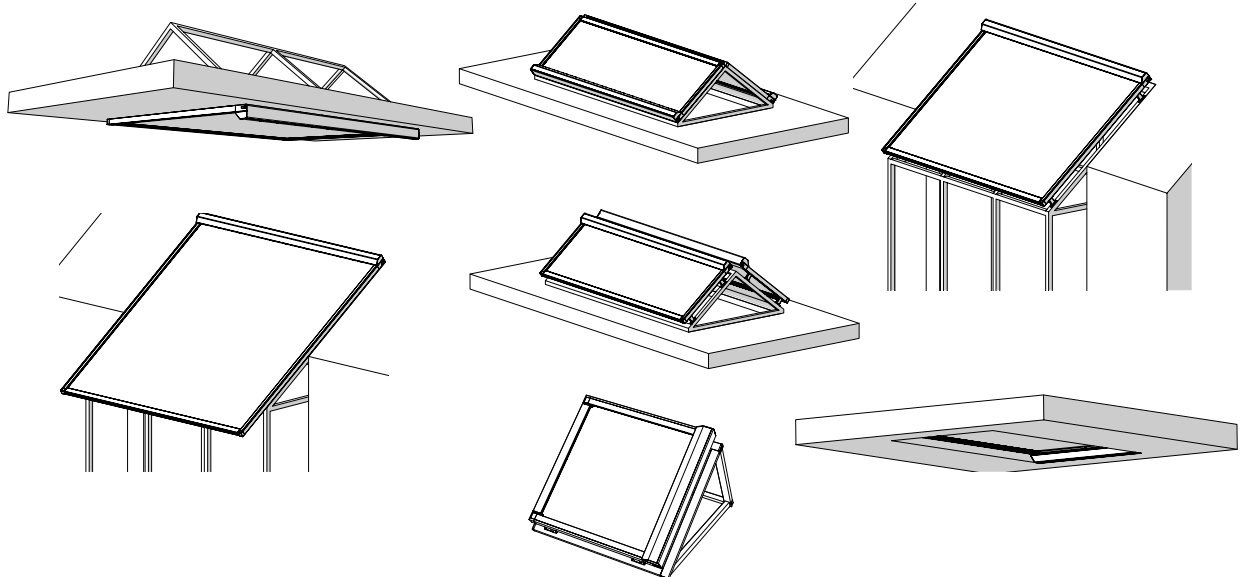
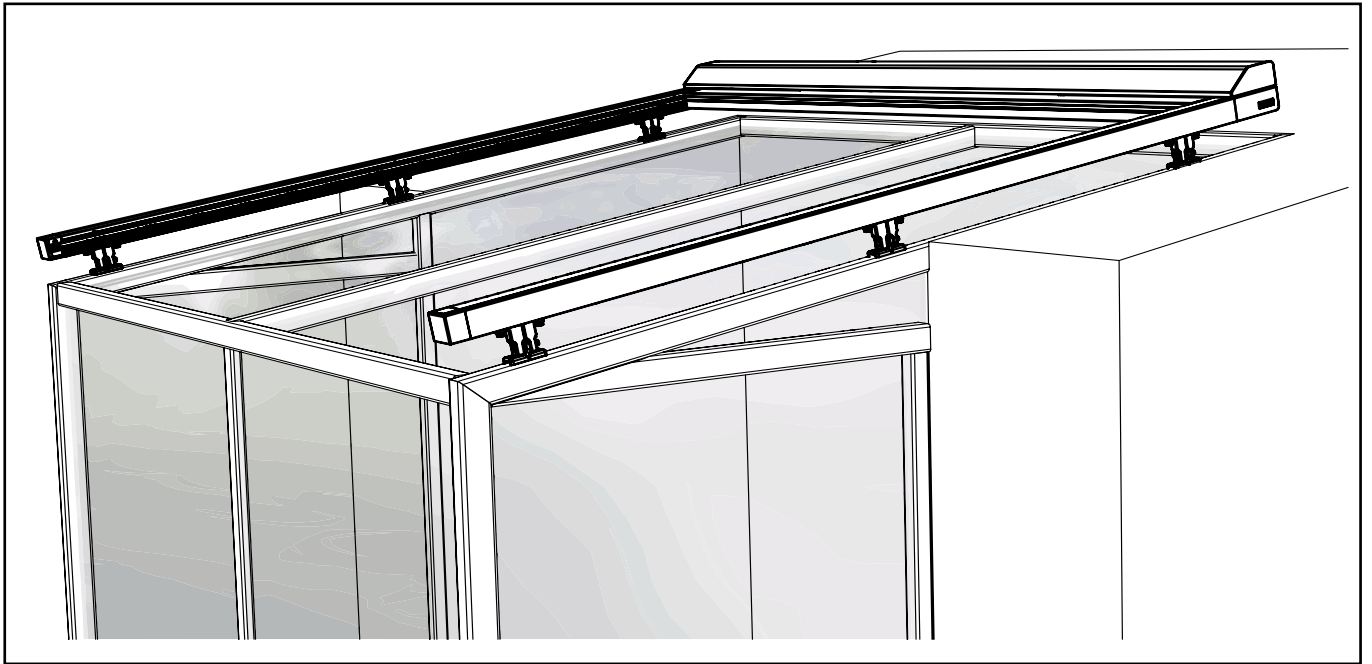
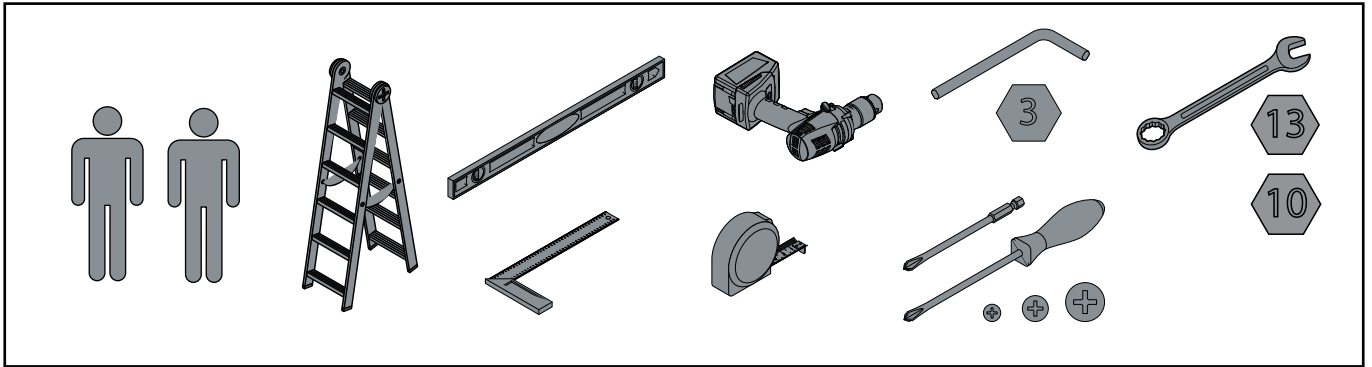

MT1



$\alpha = 0^\circ - 45^\circ$

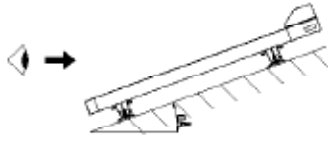

MT2



$\alpha = 1^\circ - 45^\circ$



MT3



$\alpha = 46^\circ - 135^\circ$

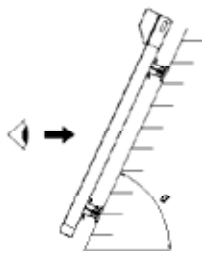

MT4



$\alpha = 46^\circ - 135^\circ$

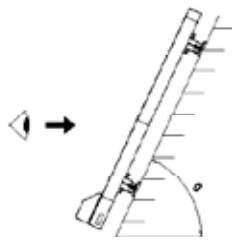

MT5



$\alpha = 0^\circ - 90^\circ$

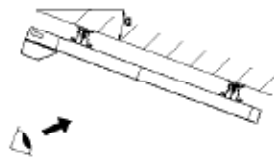

MT6



$\alpha = 1^\circ - 90^\circ$

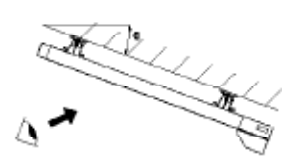

MT7



$\alpha = 1^\circ - 90^\circ$

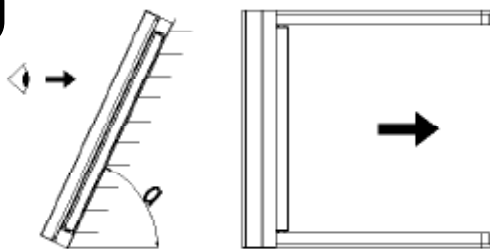

MT8



$\alpha = 1^\circ - 90^\circ$

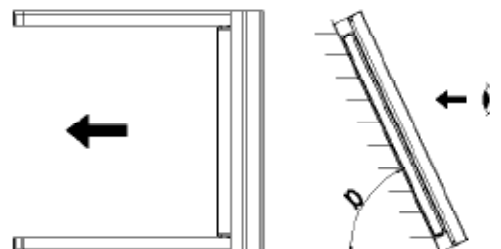

MT9



$\alpha = 1^\circ - 90^\circ$

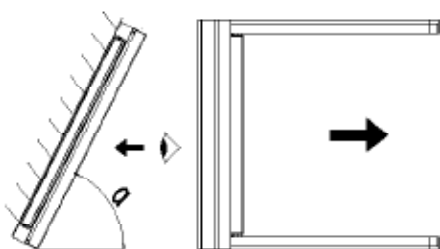

MT10



$\alpha = 1^\circ - 90^\circ$

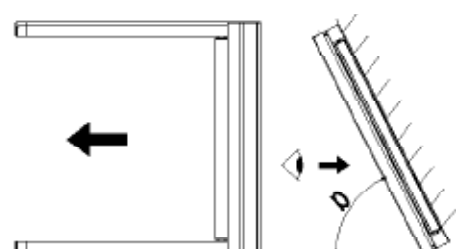

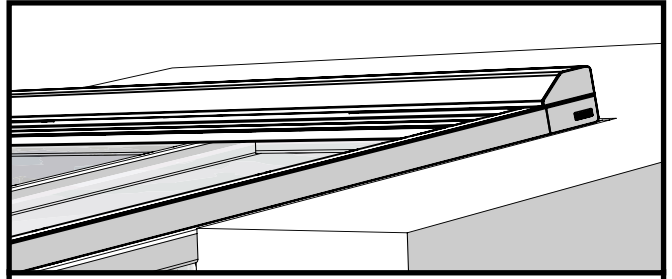
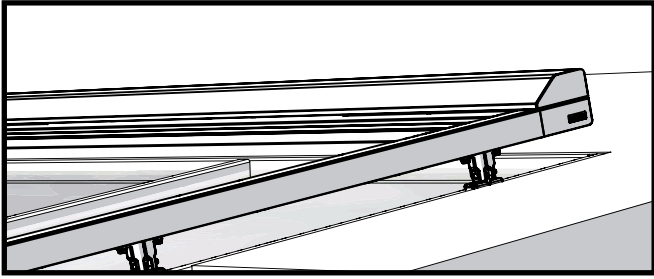

1

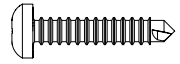
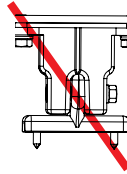
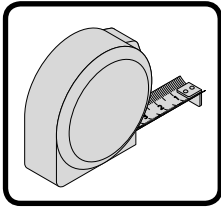

DIN 7981
4.8 x 22 mm

B

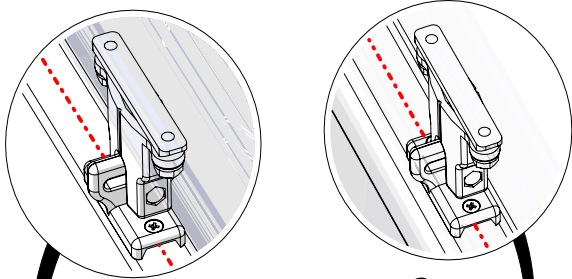

B-40mm

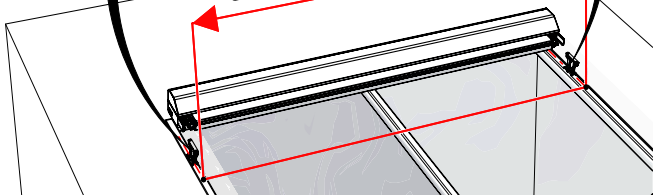

B

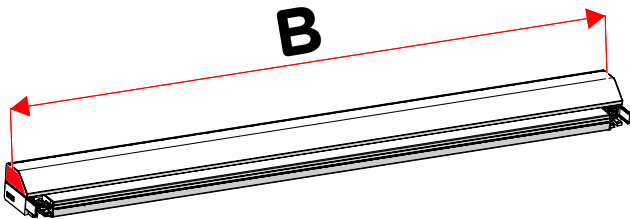

A 168

A 167

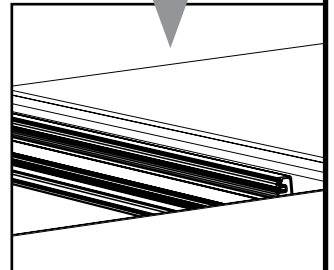
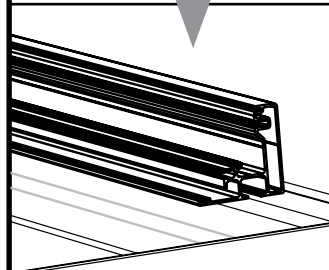
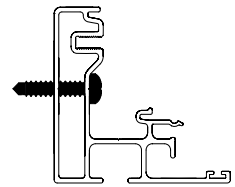
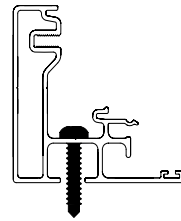
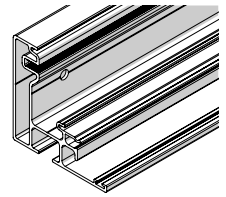
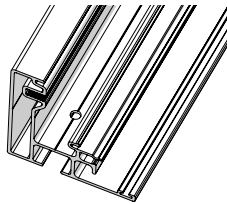

4

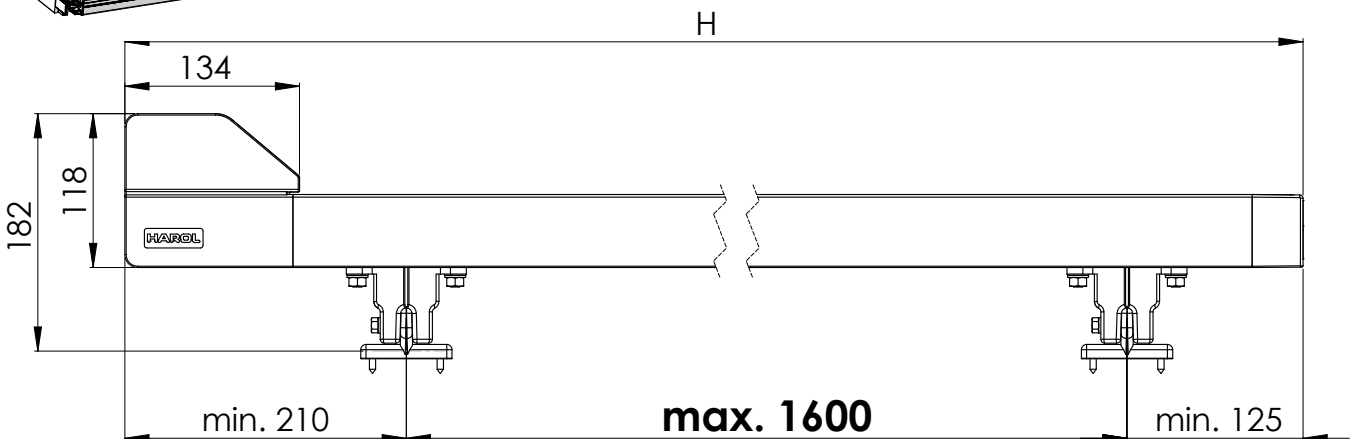

MONTAGE - MOUNTING TZ330

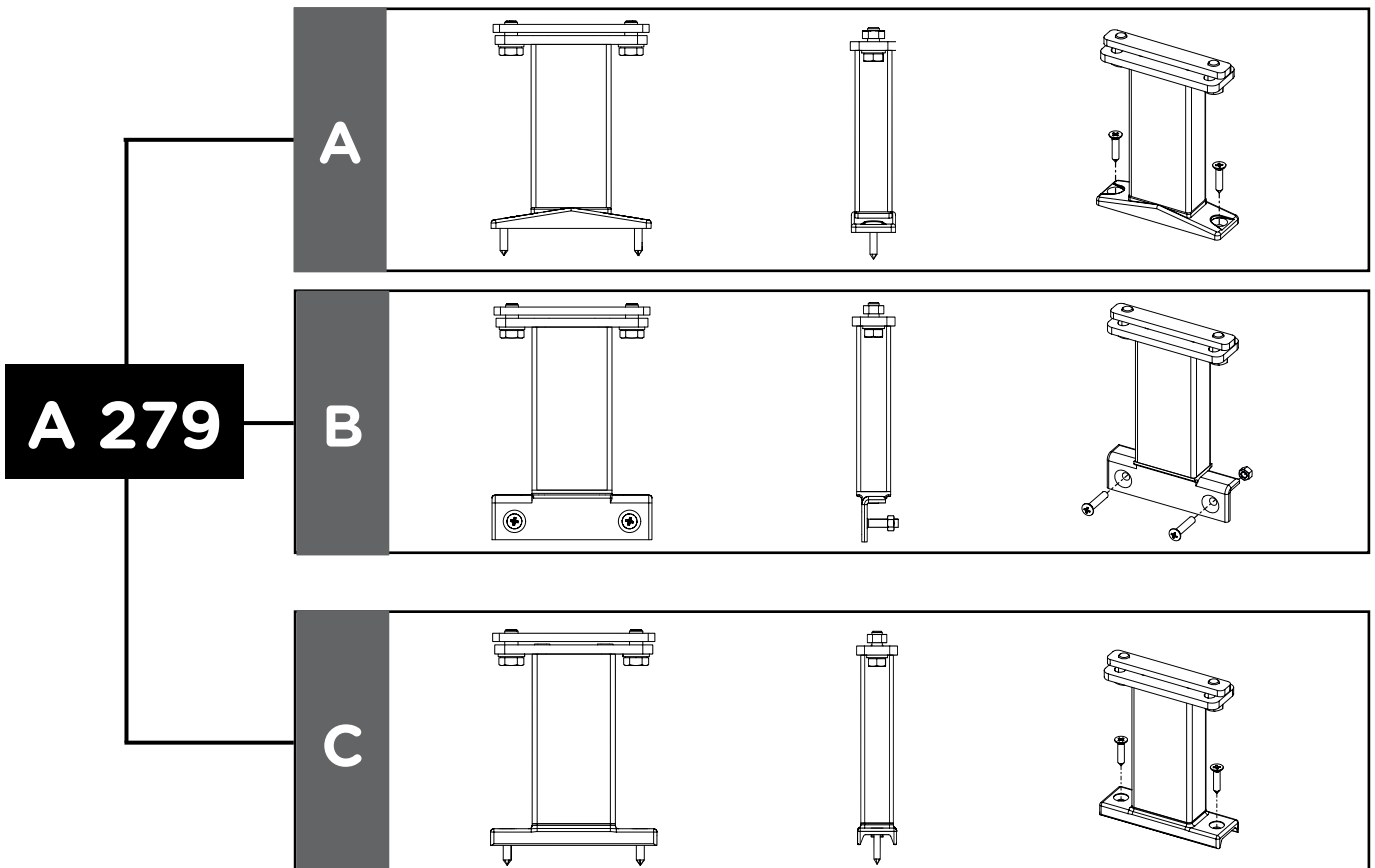
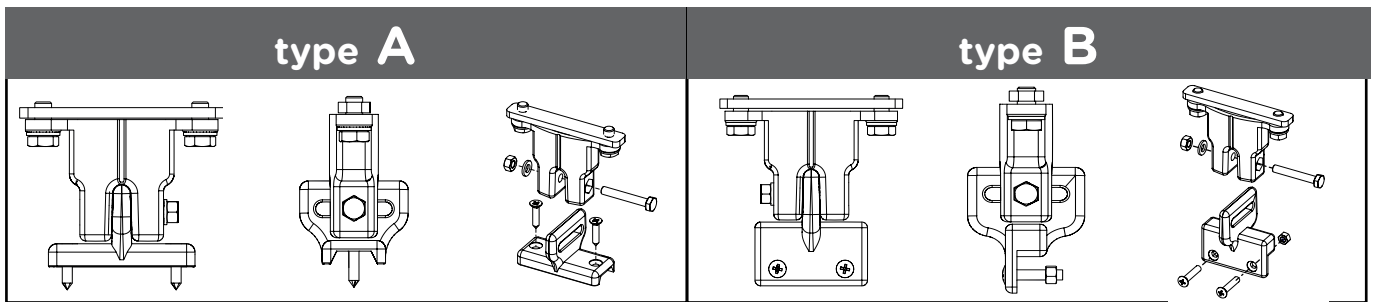
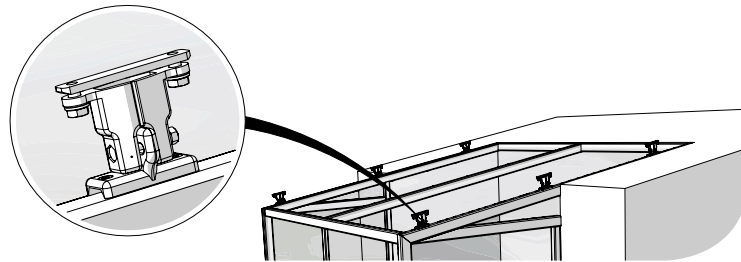
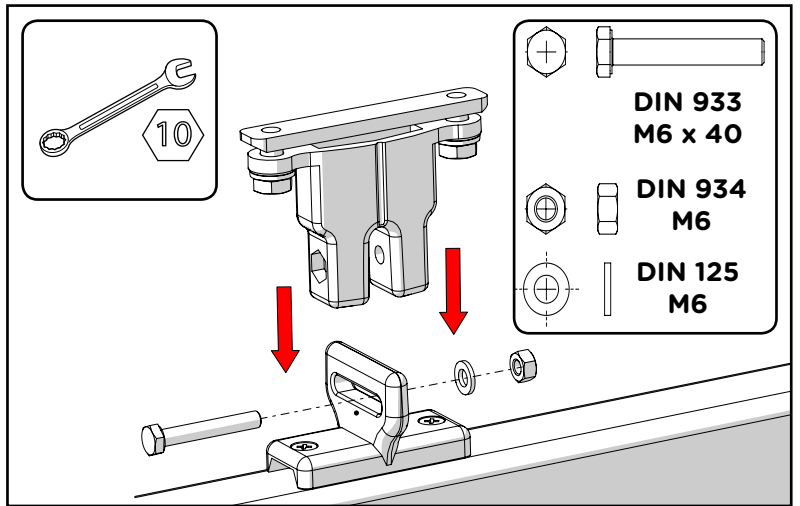
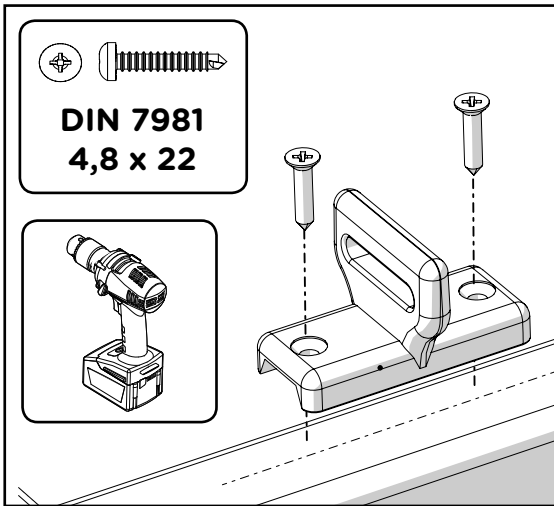

2

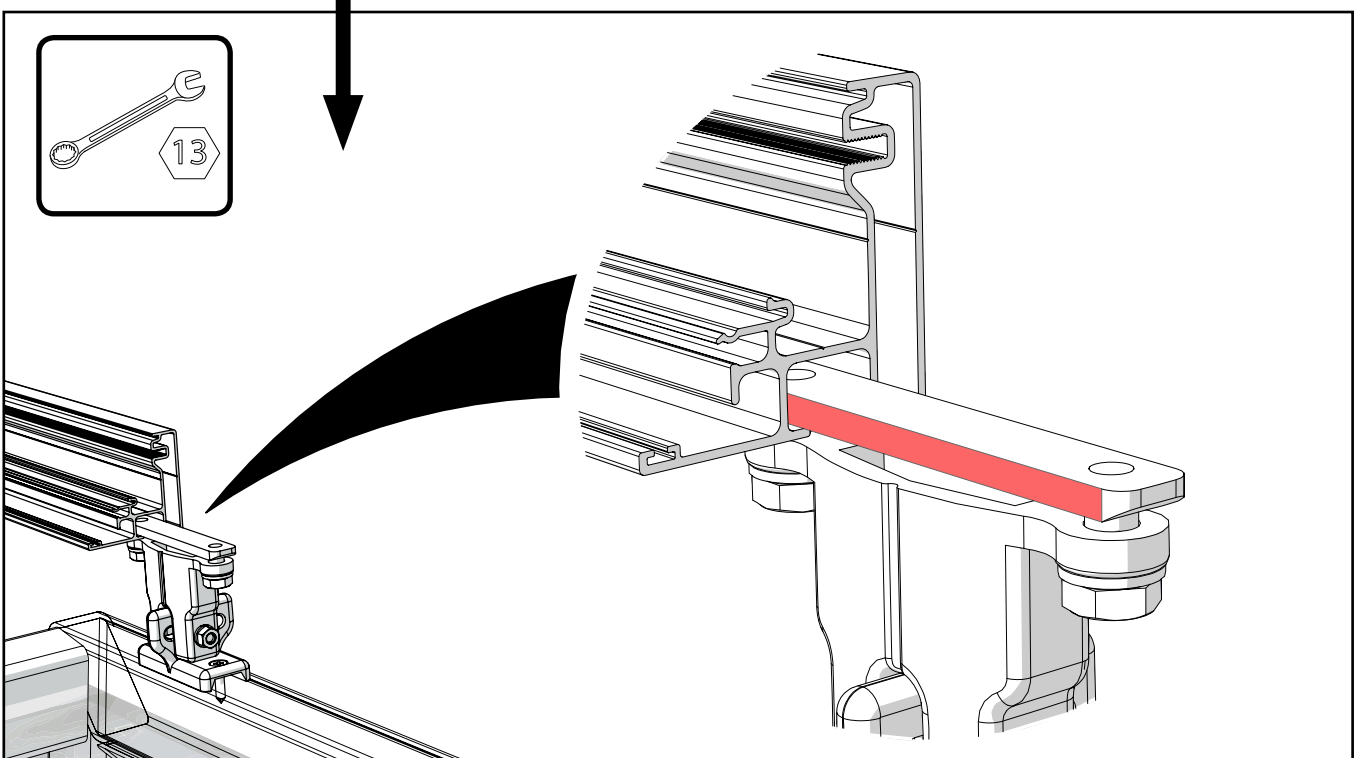
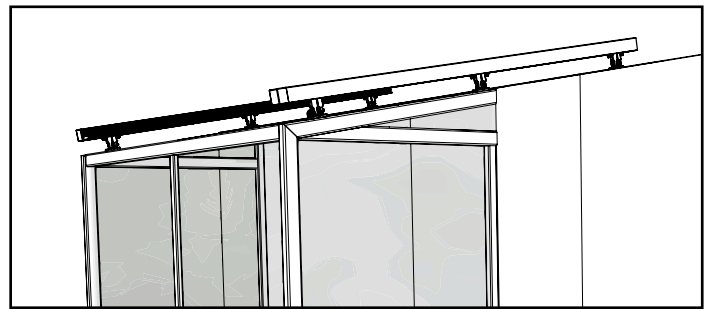
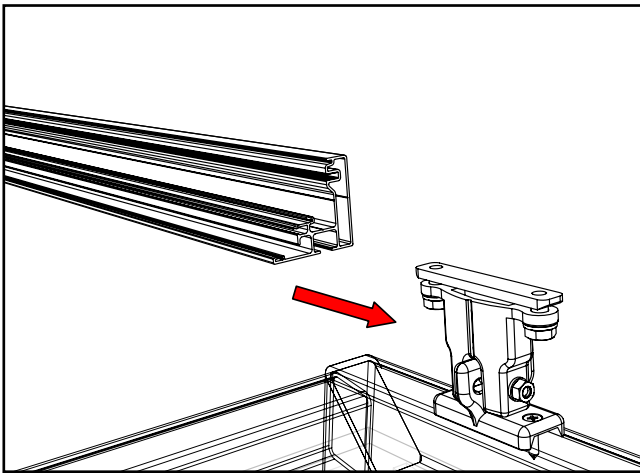
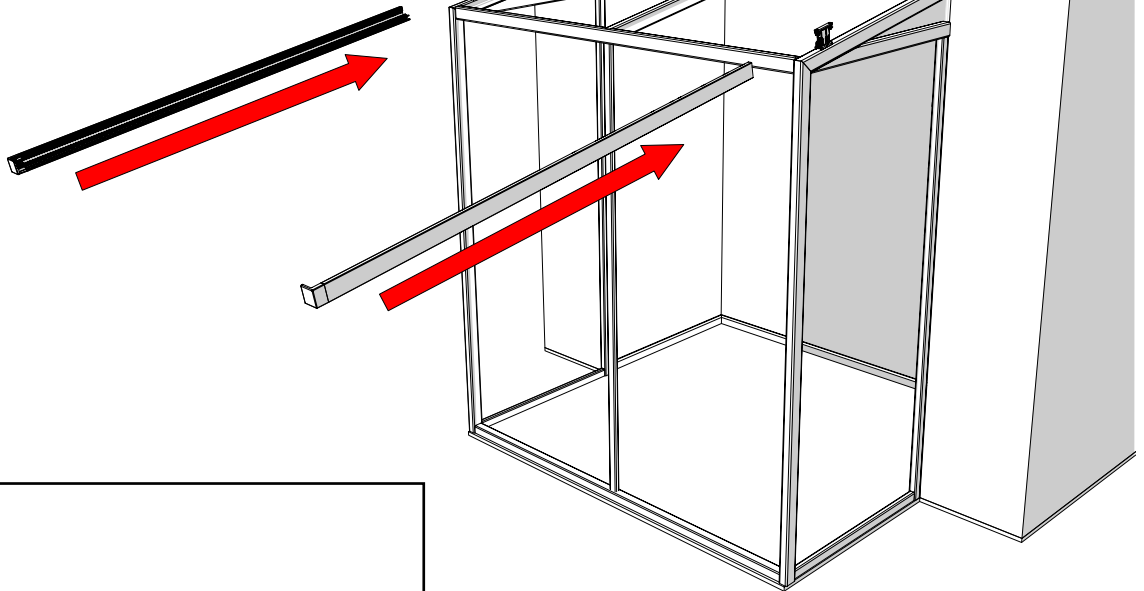
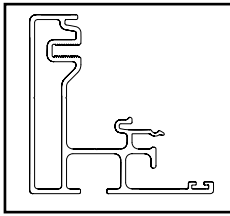

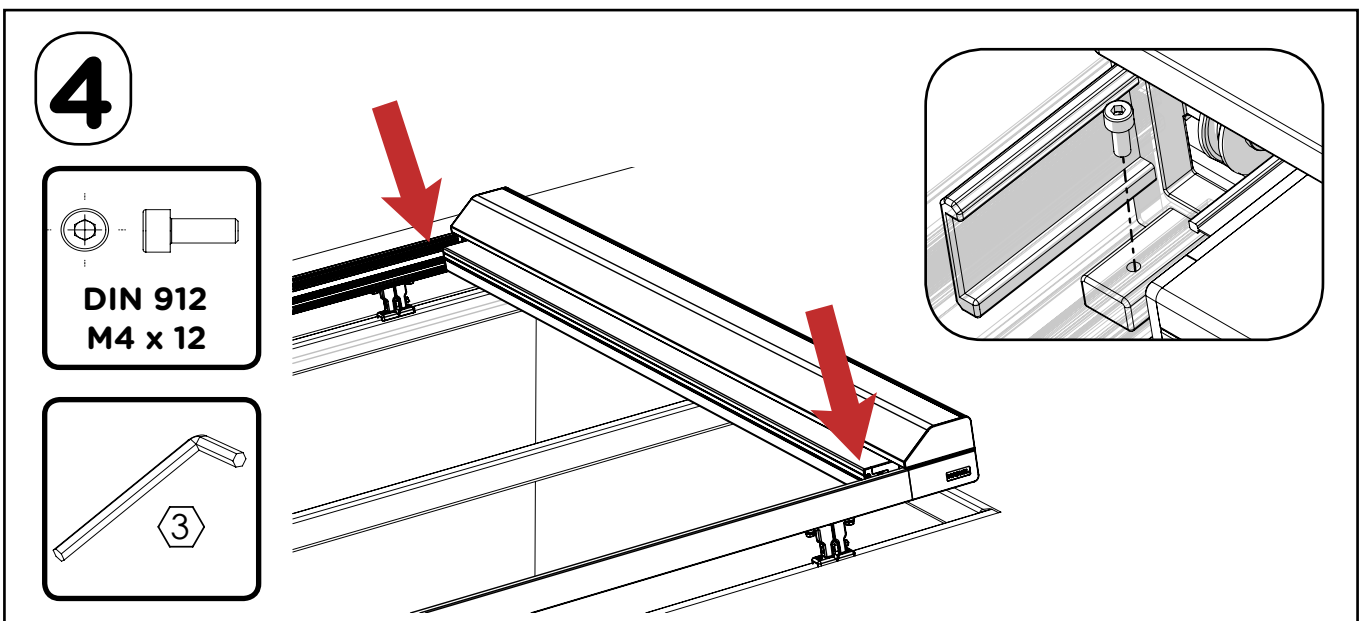
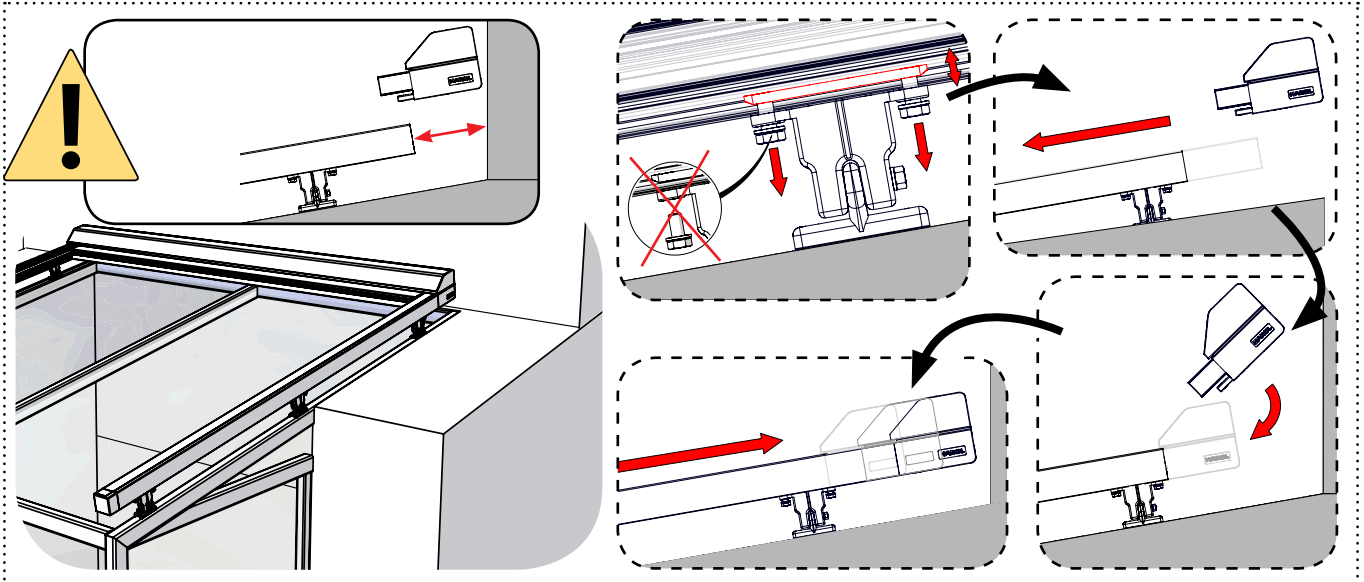
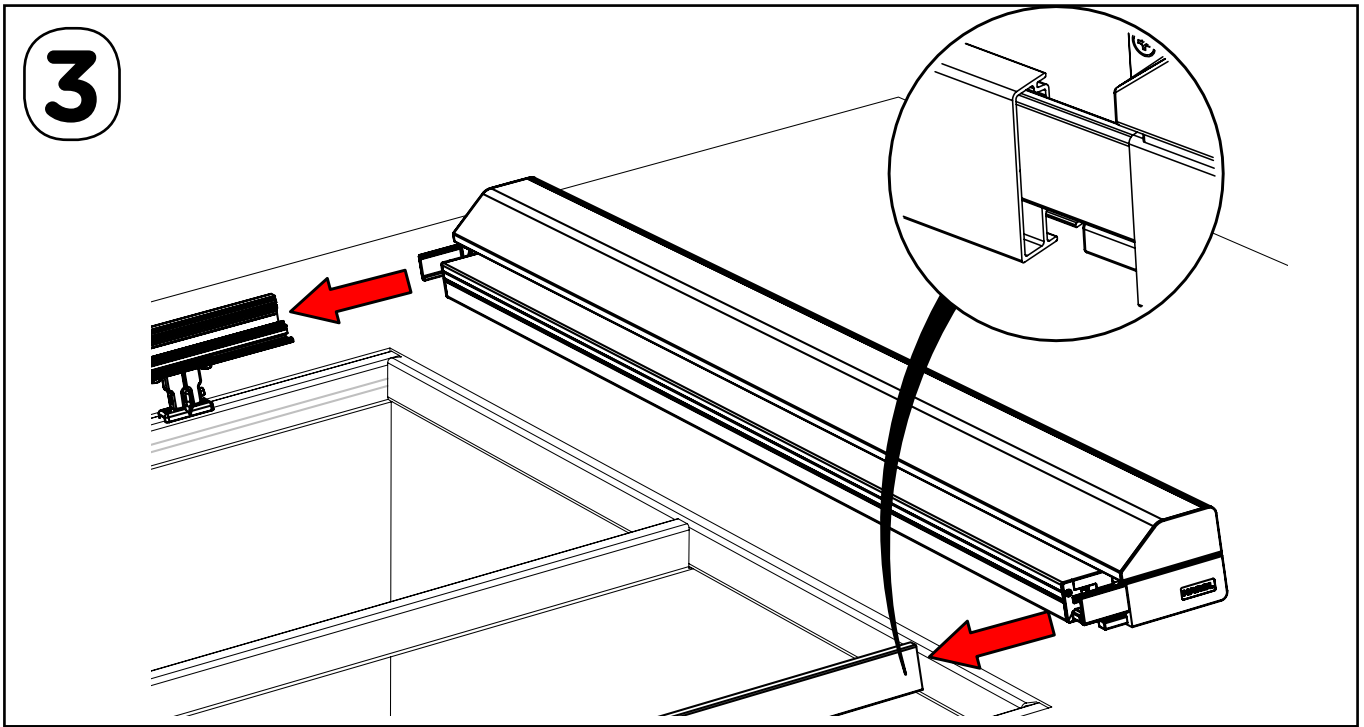

5 KONTROLL

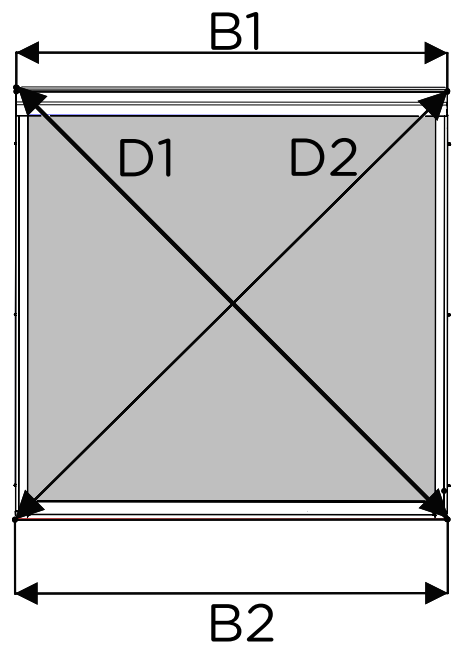
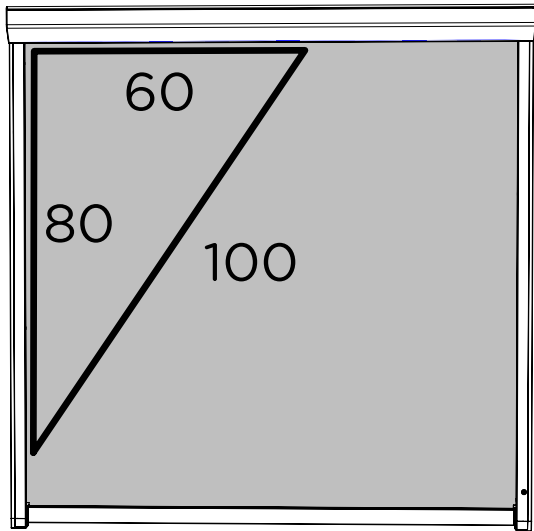

B1 = B2 & D1 = D2
 (+/- 2mm) (+/- 2mm)

6

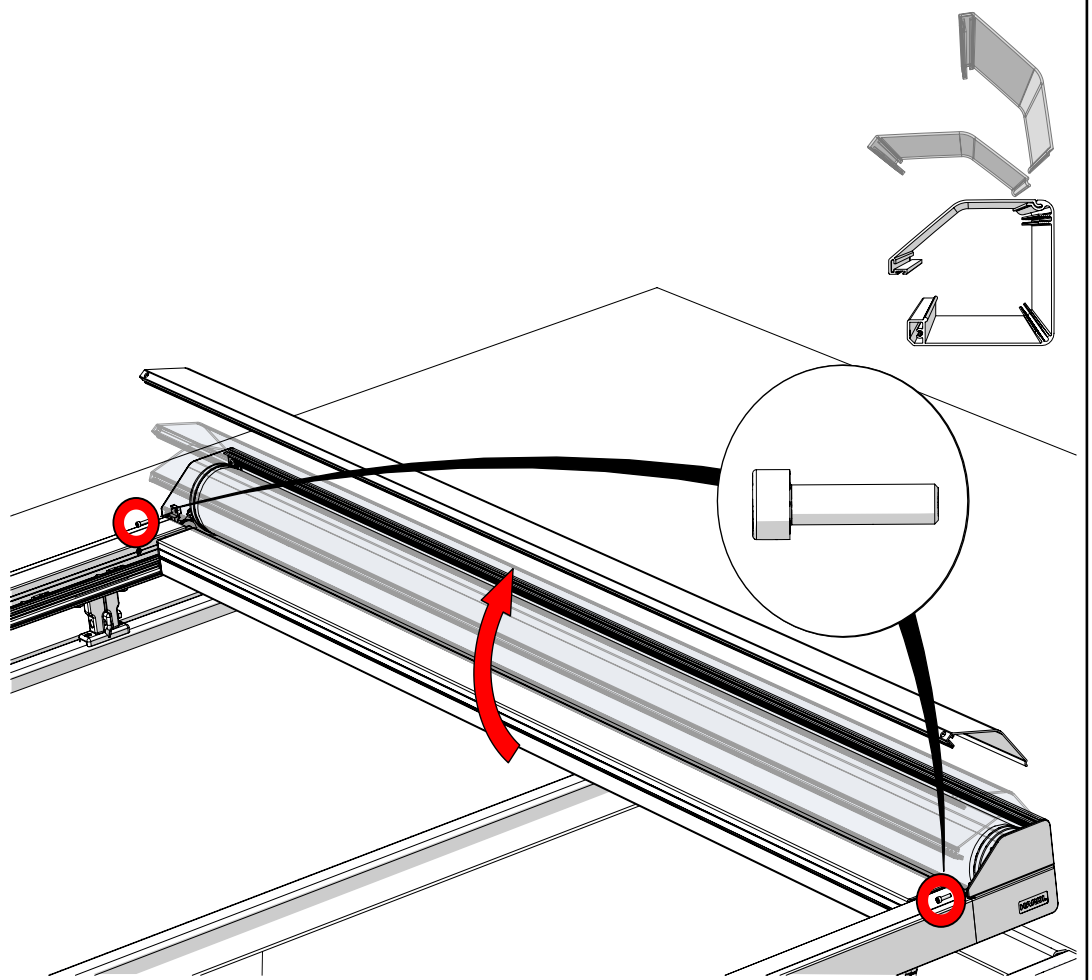
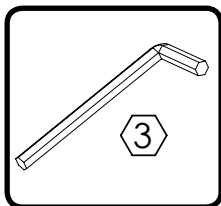
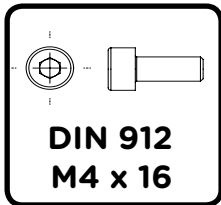
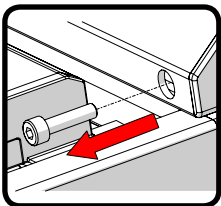

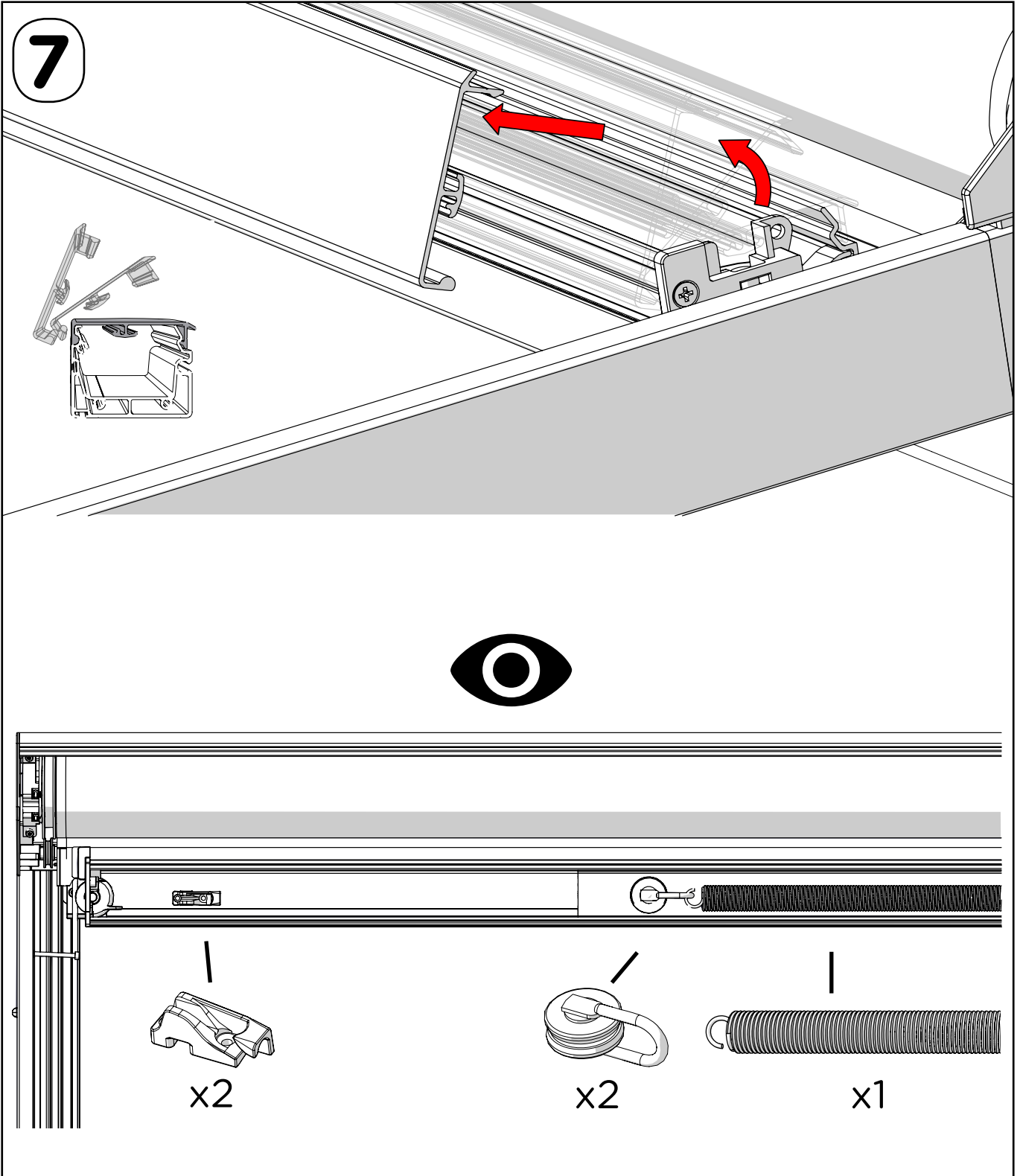

8

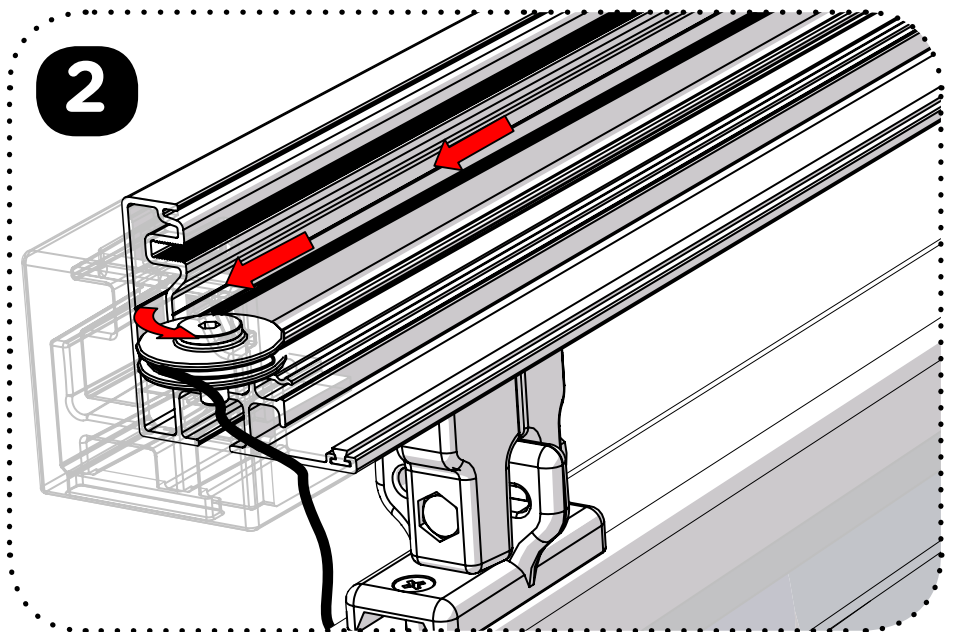
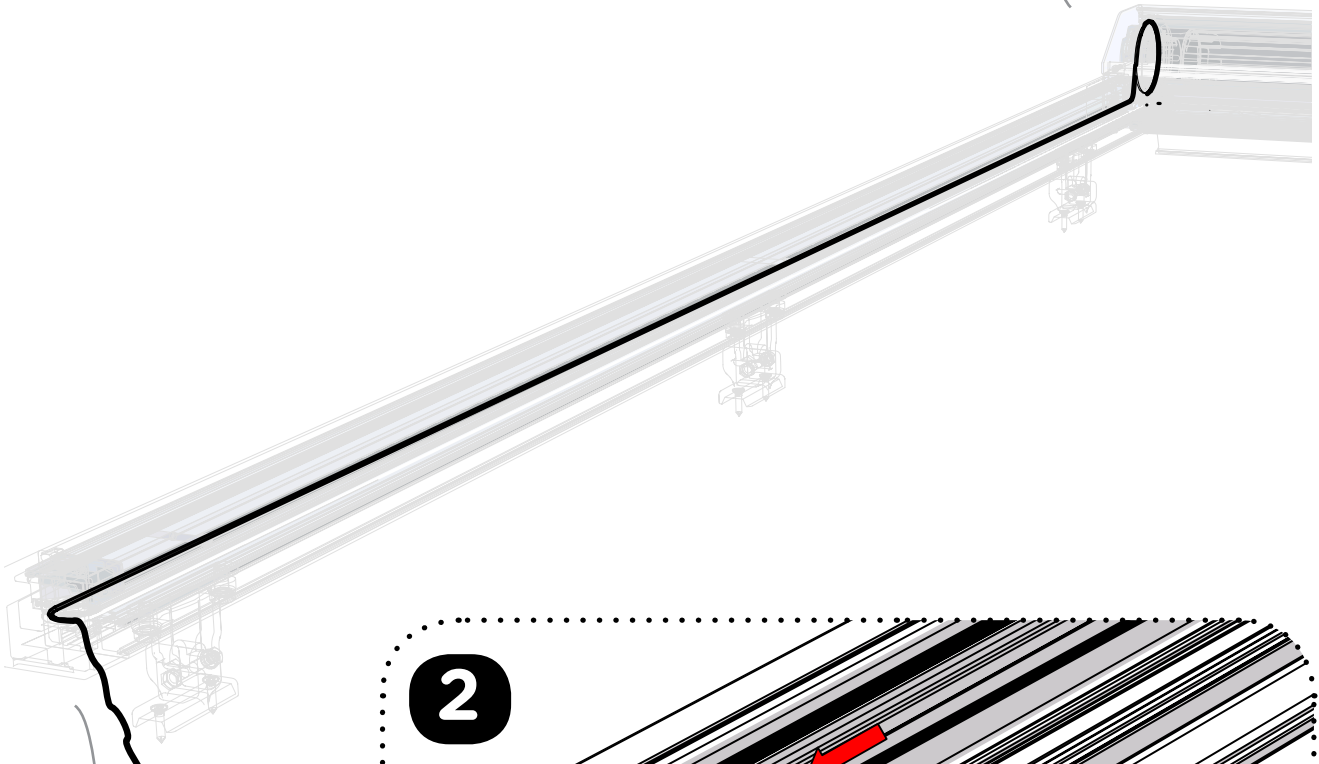
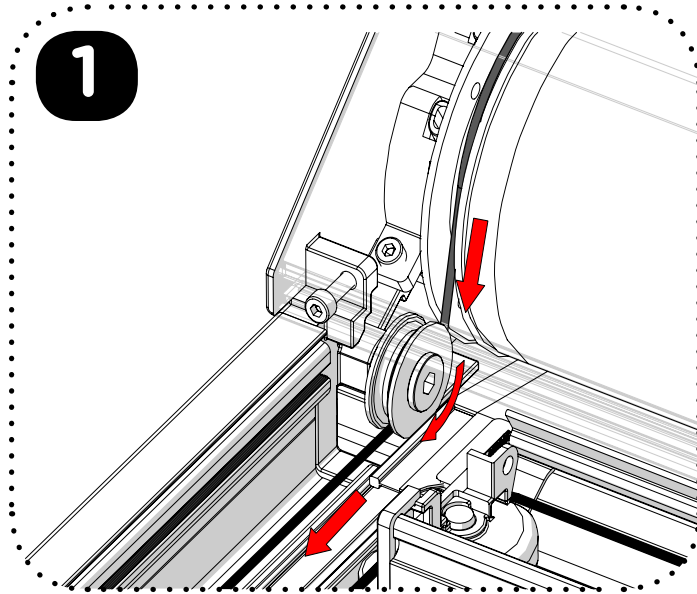
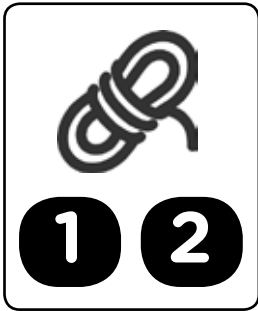

9

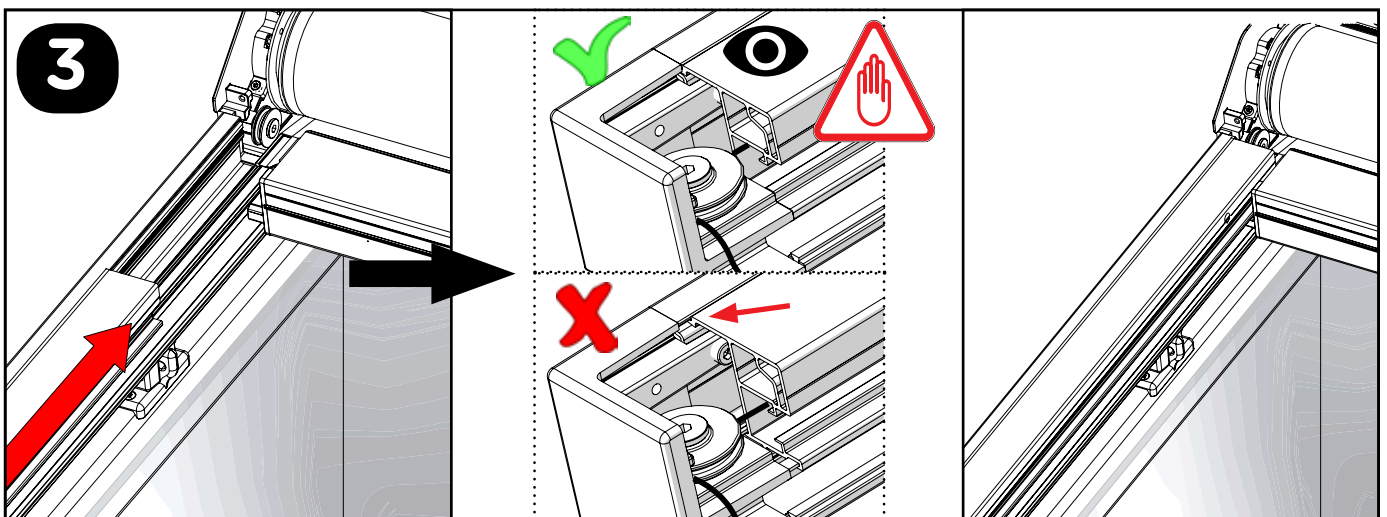
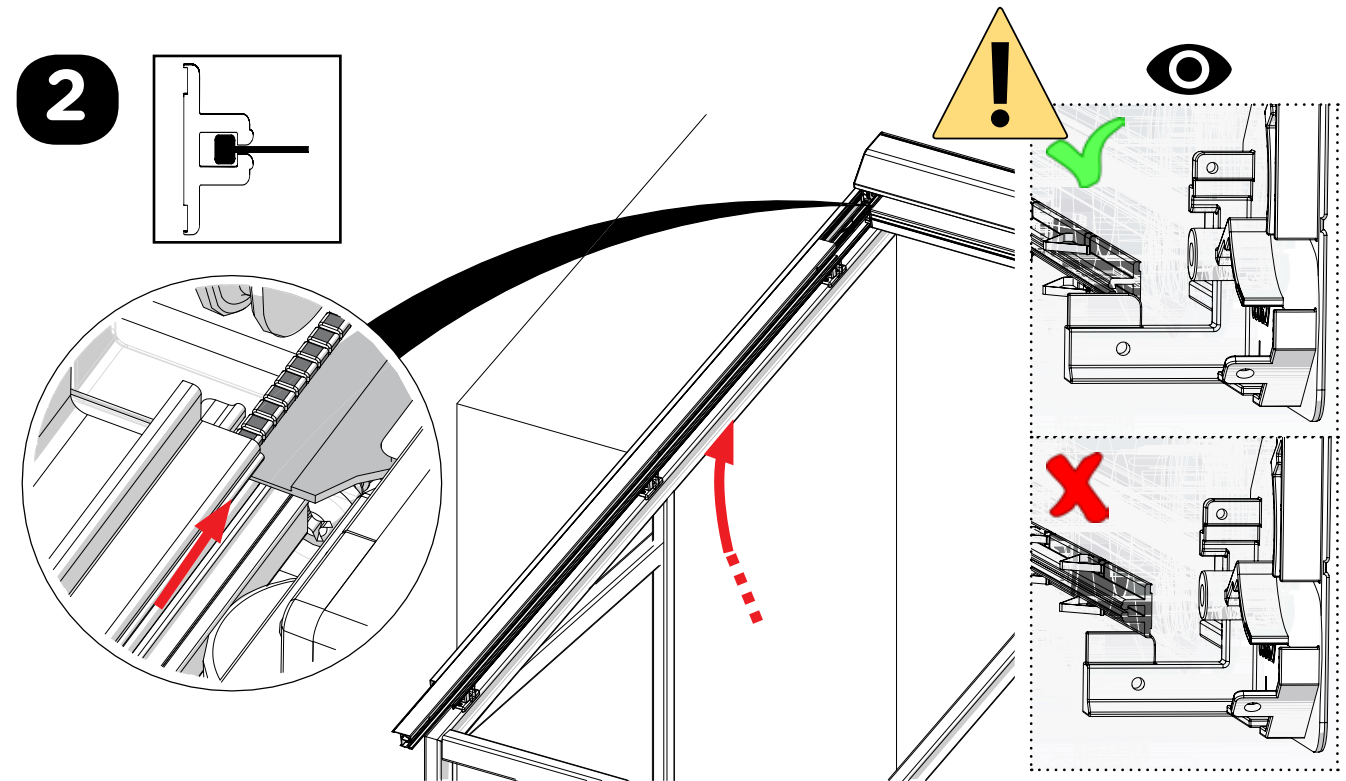
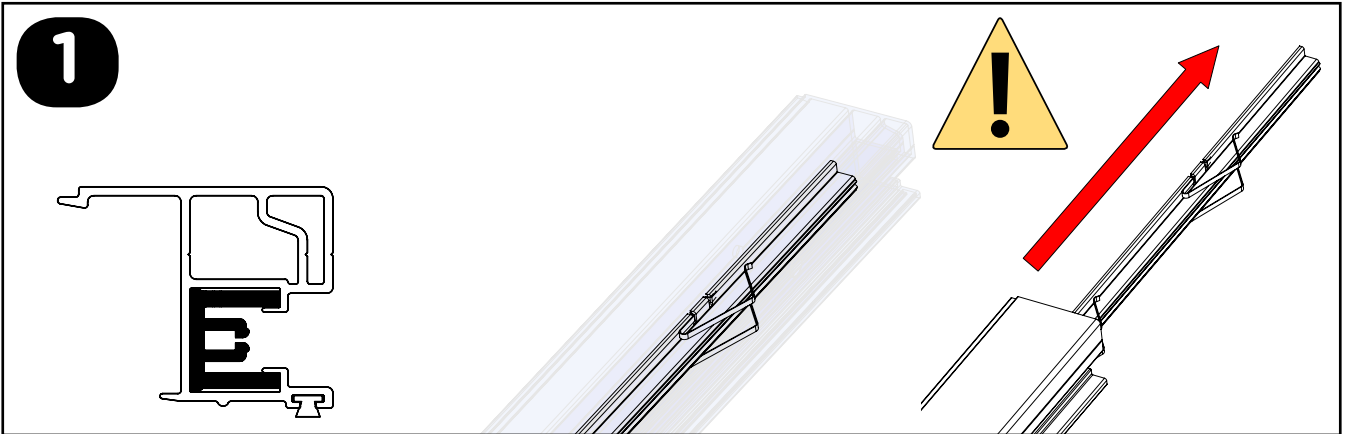

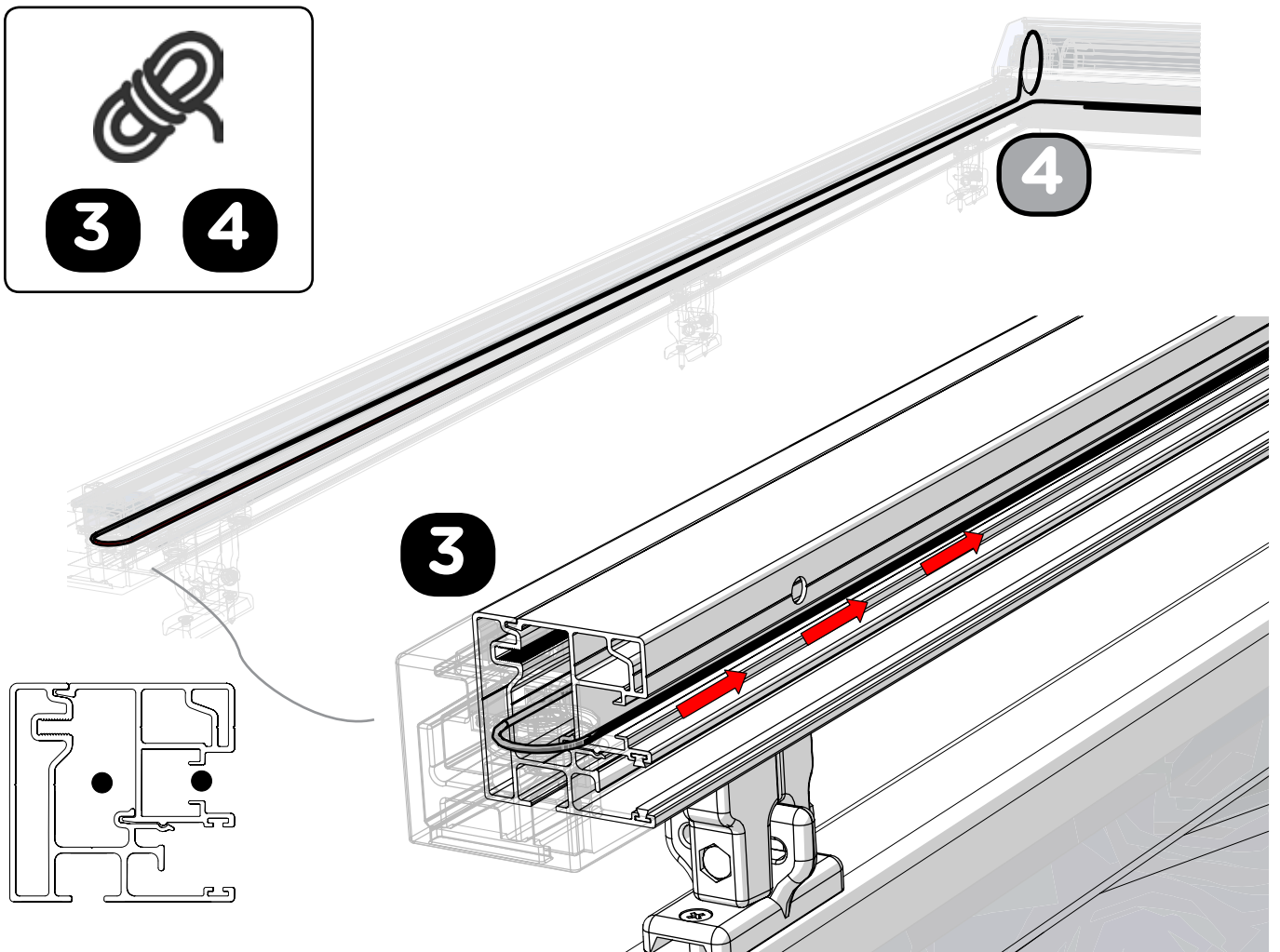
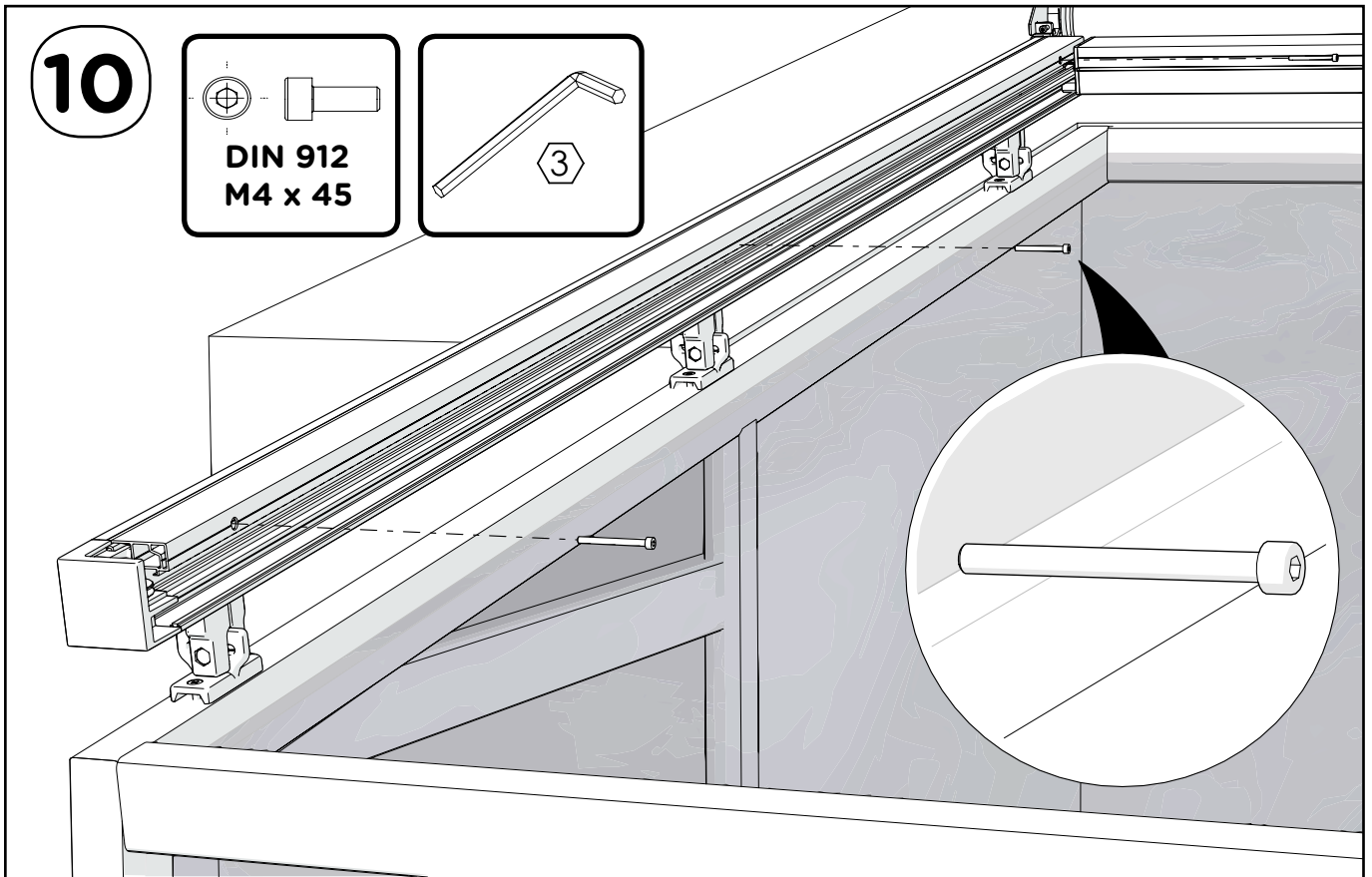

4

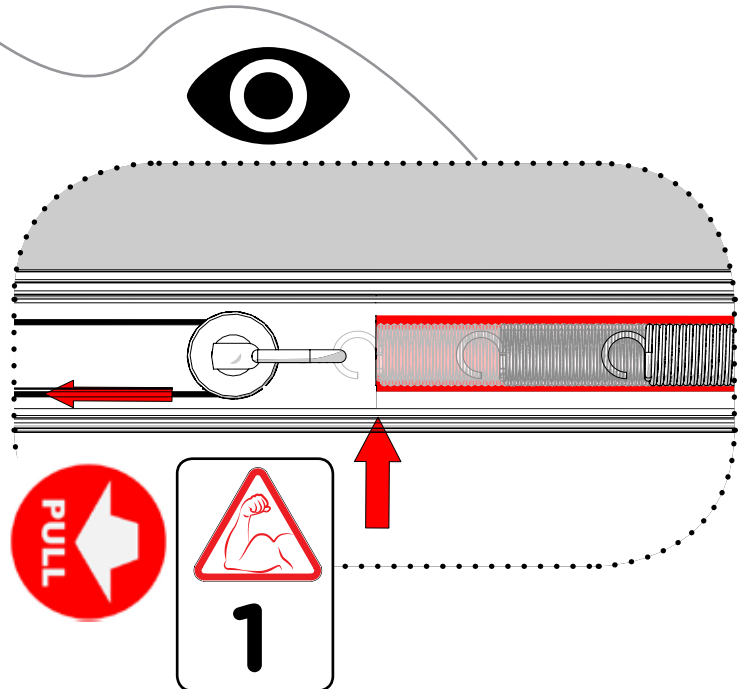
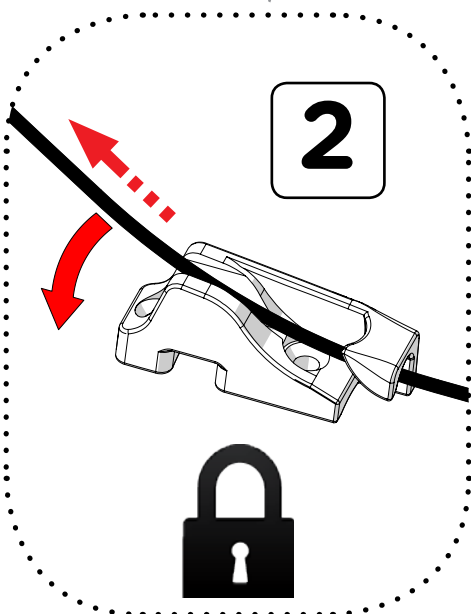
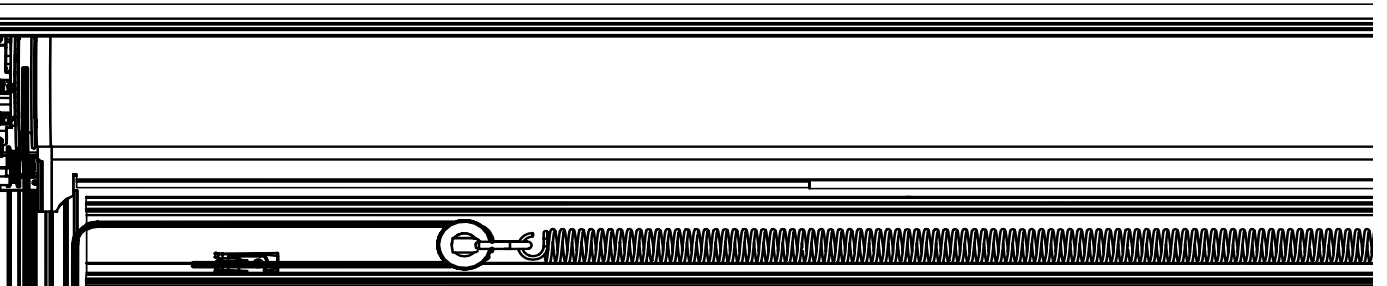
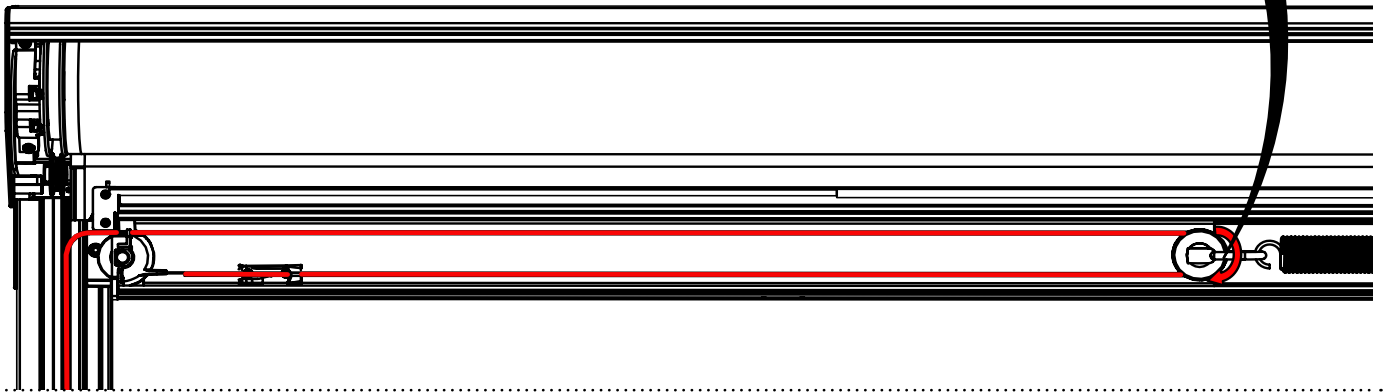
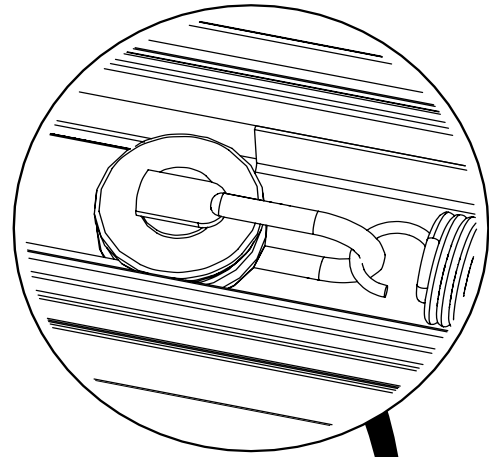
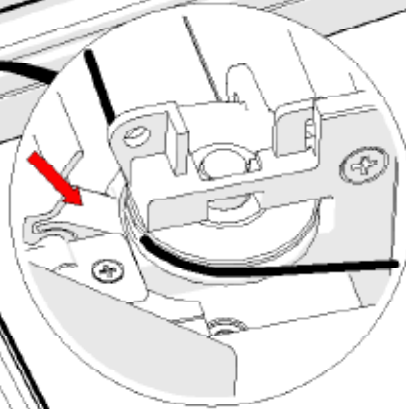
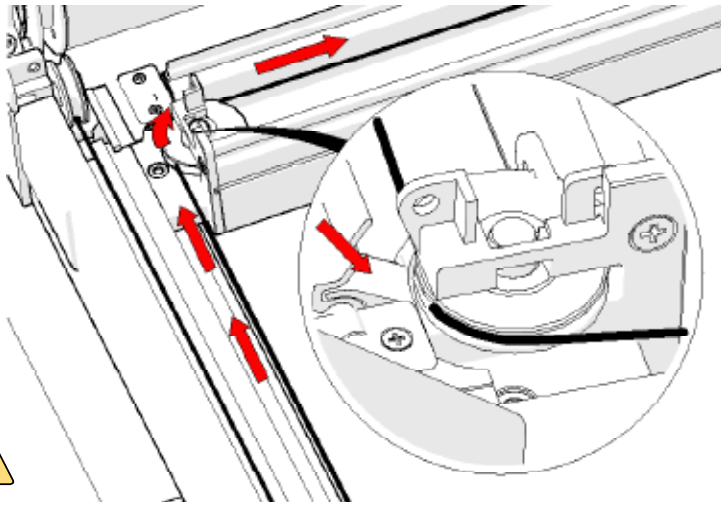

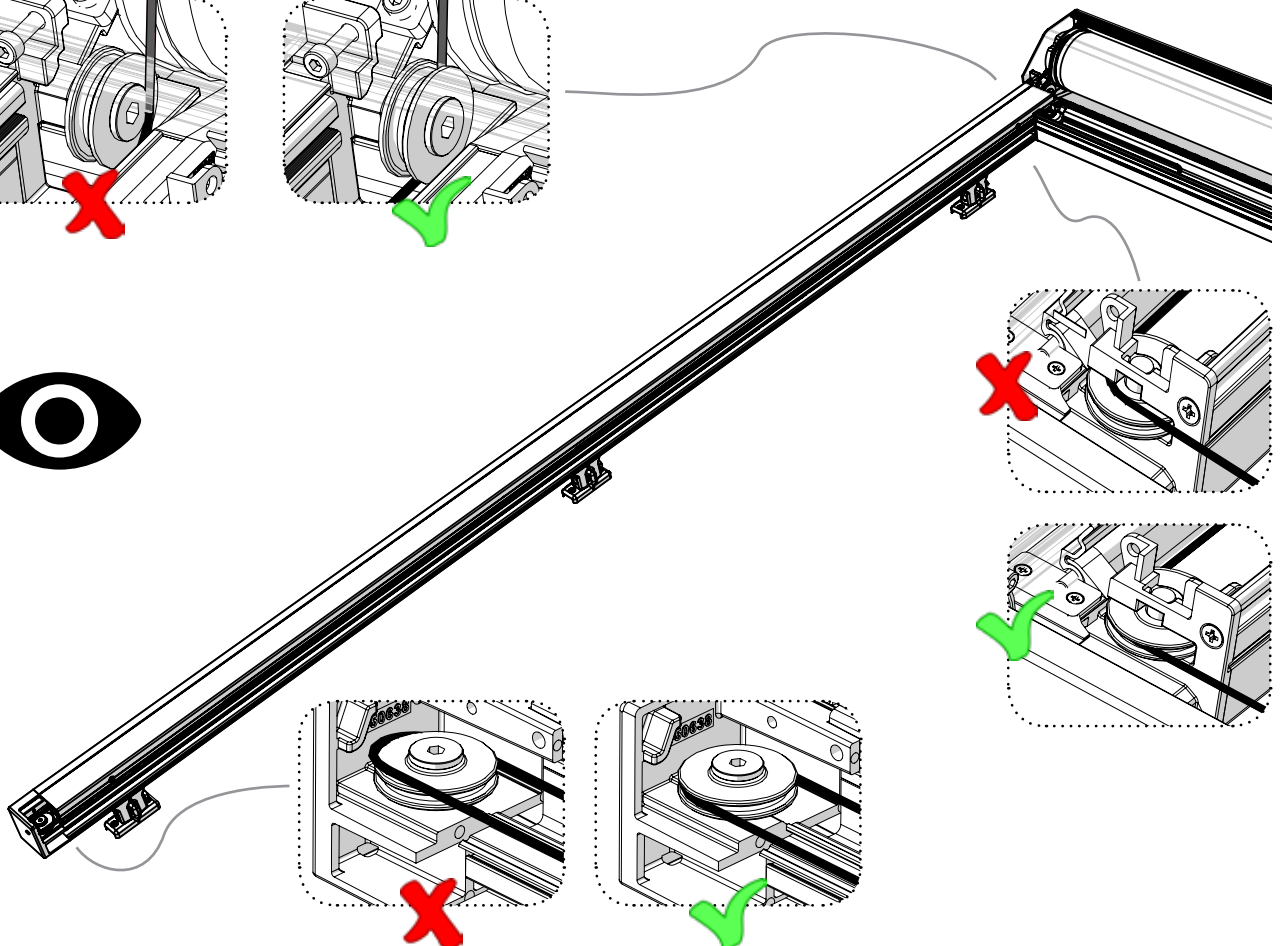
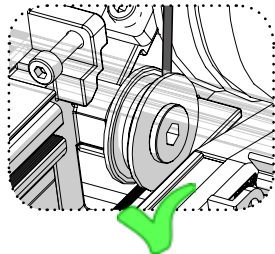
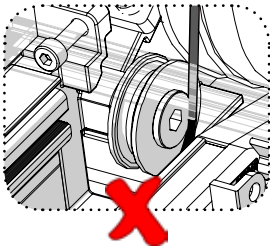
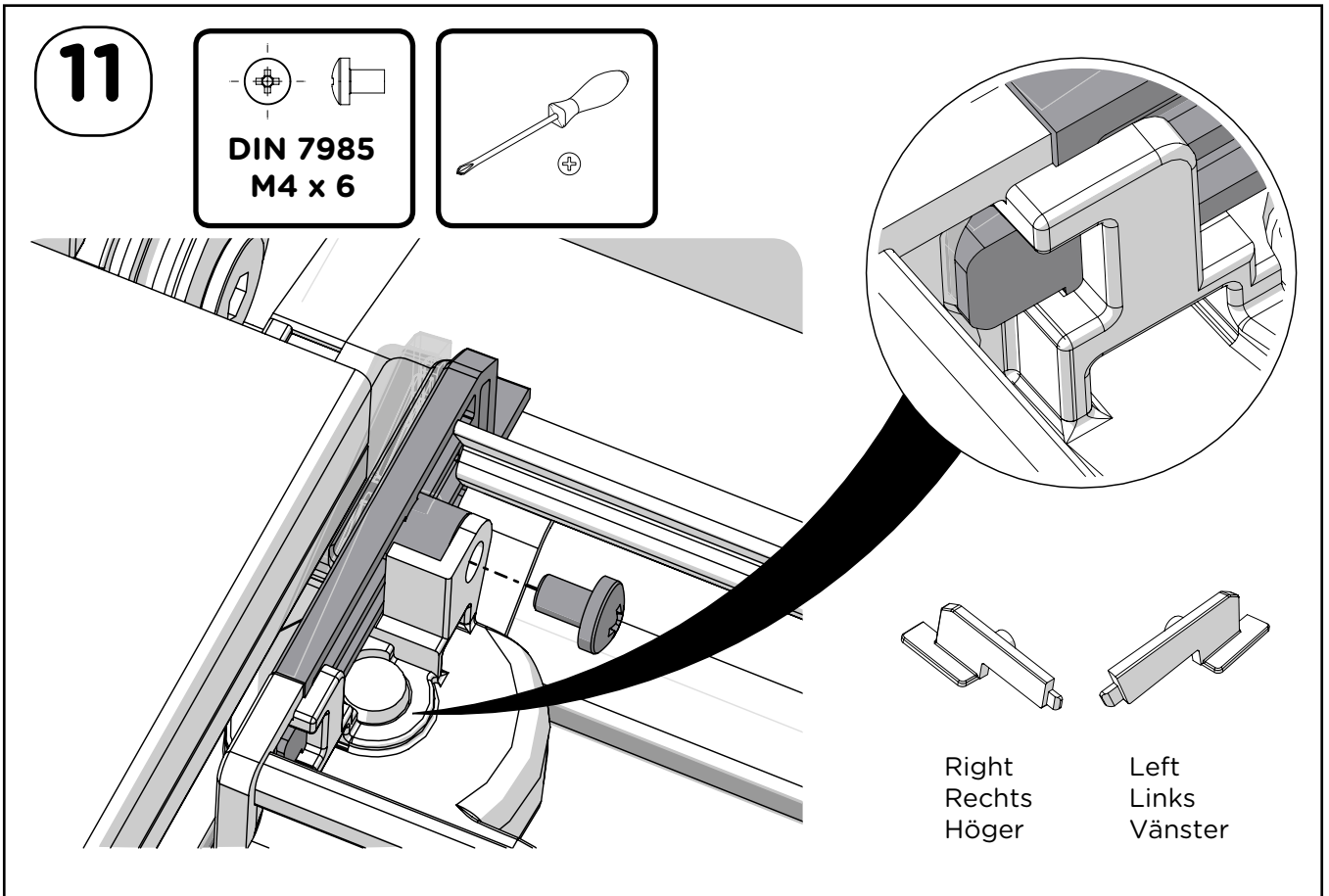

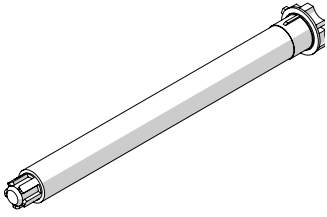

somfy.

www.somfy.com



see instruction manual Somfy (included)
 Se instruktioner från Somfy (inkluderat)
 voir manuel d'instruction Somfy (inclus)
 siehe Bedienungsanleitung Somfy (inbegriffen)

OREA 50 WT 25/17
 OREA 50 WT 40/17
 Gemini 25/17 SLT50
 Mariner 40/17 SLT50
 Orea 25/17 LT50 RTS
 Orea 40/17 LT50 RTS
 Sunea 50 IO 25/17
 Sunea 50 IO 40/17

12

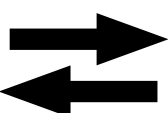

x1

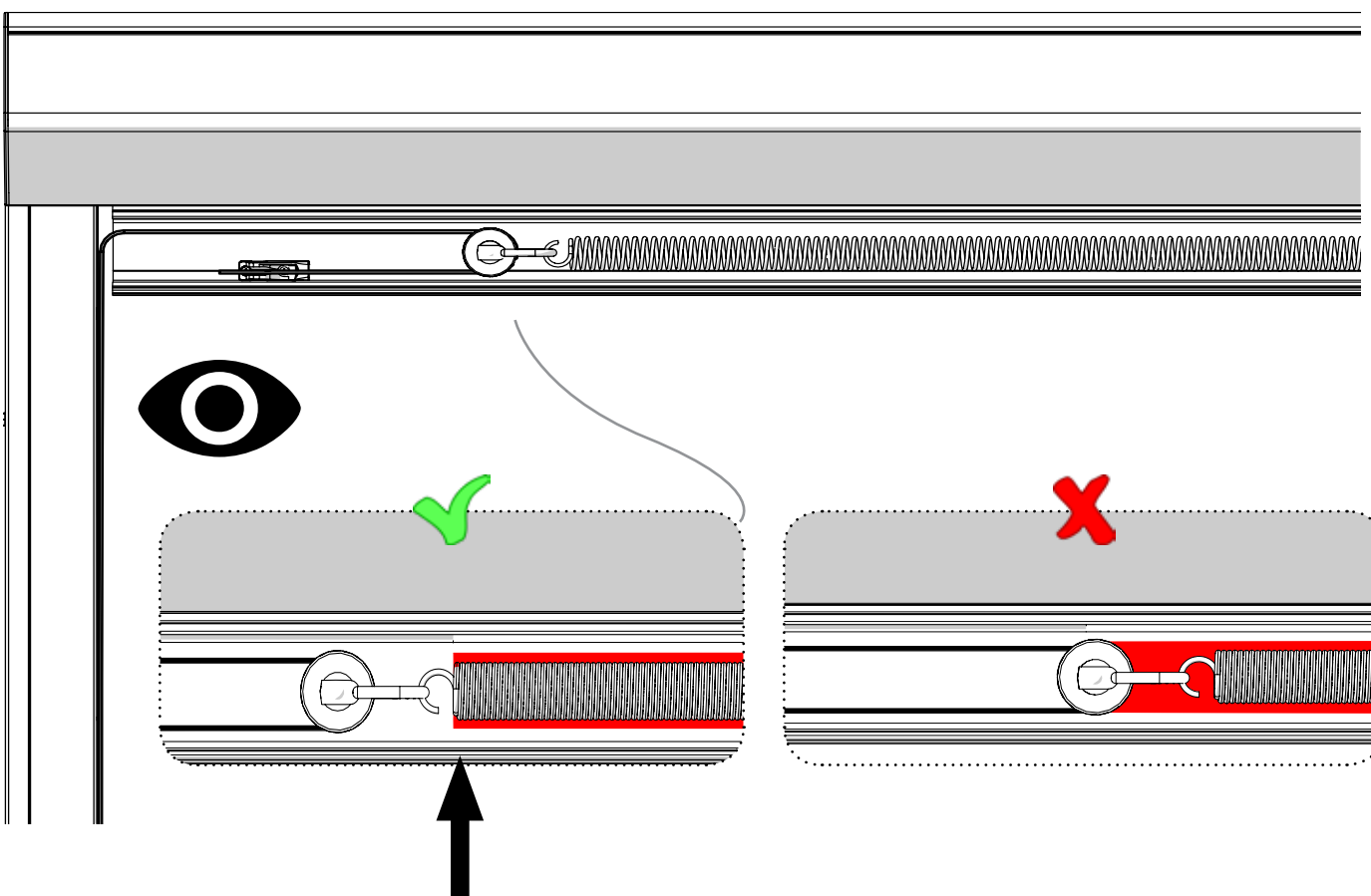
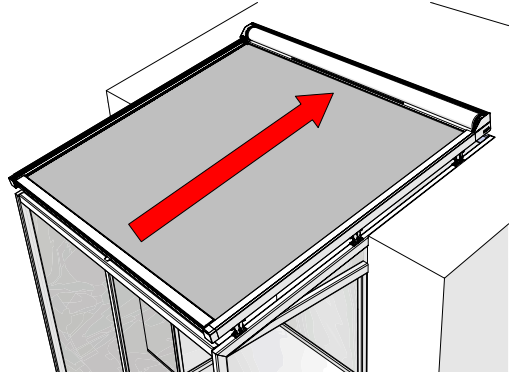
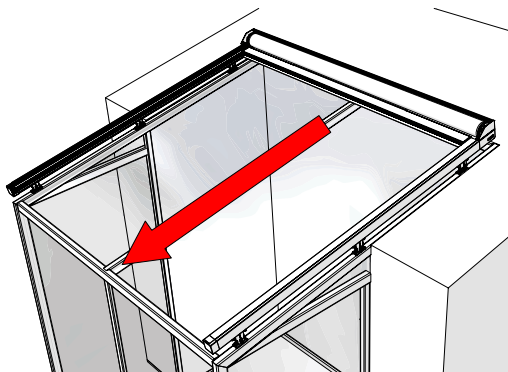

13

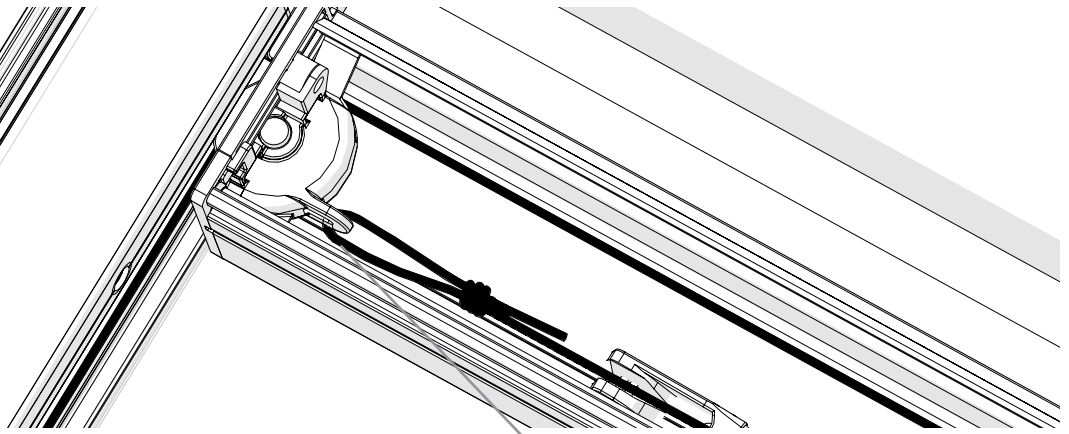
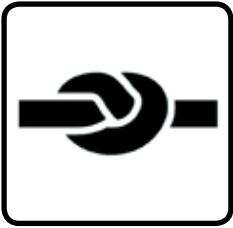

14

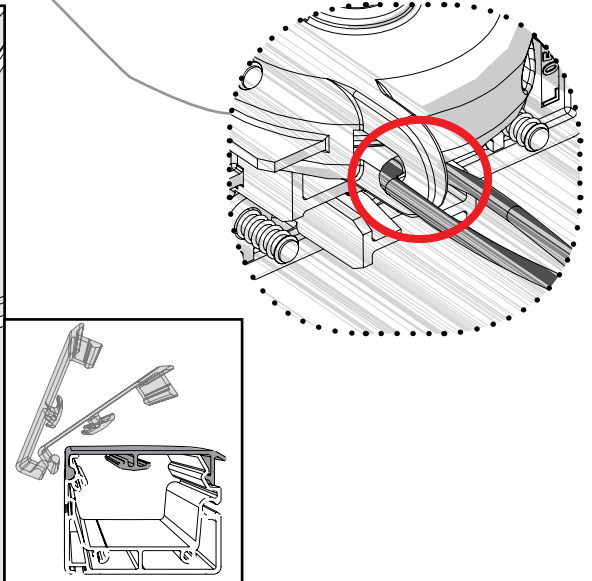
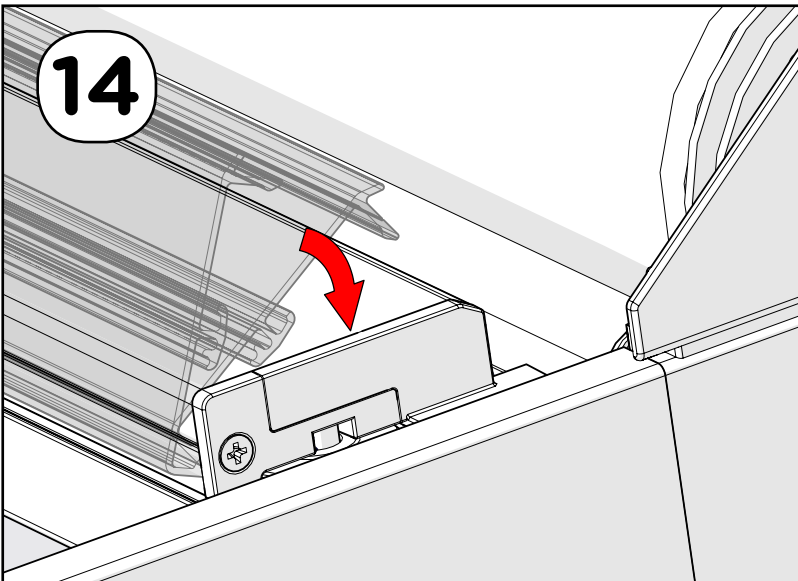

15

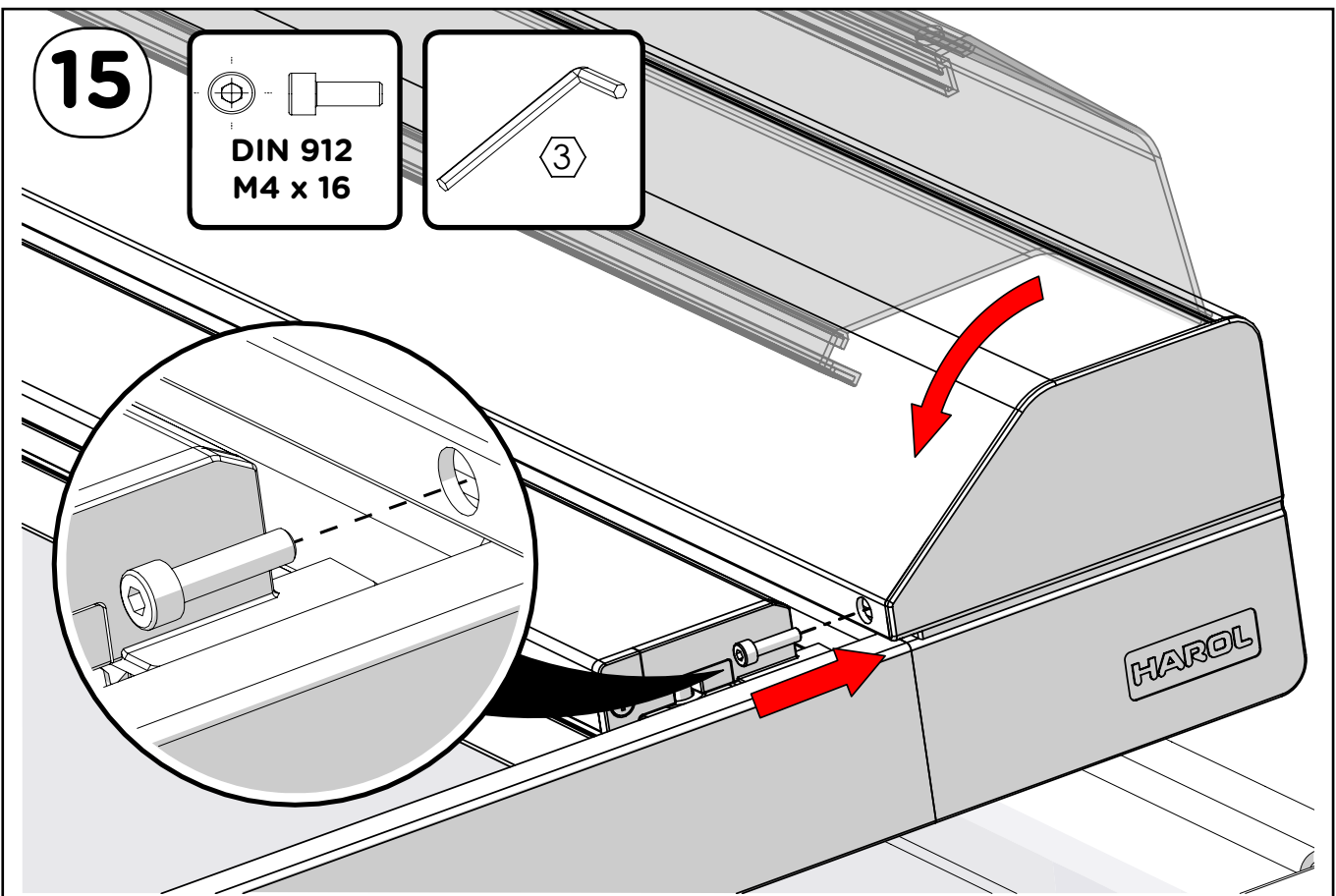
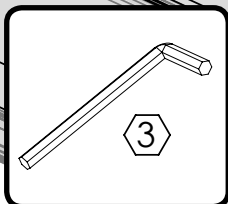
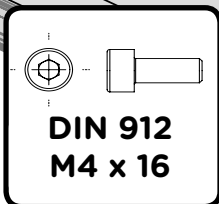

16

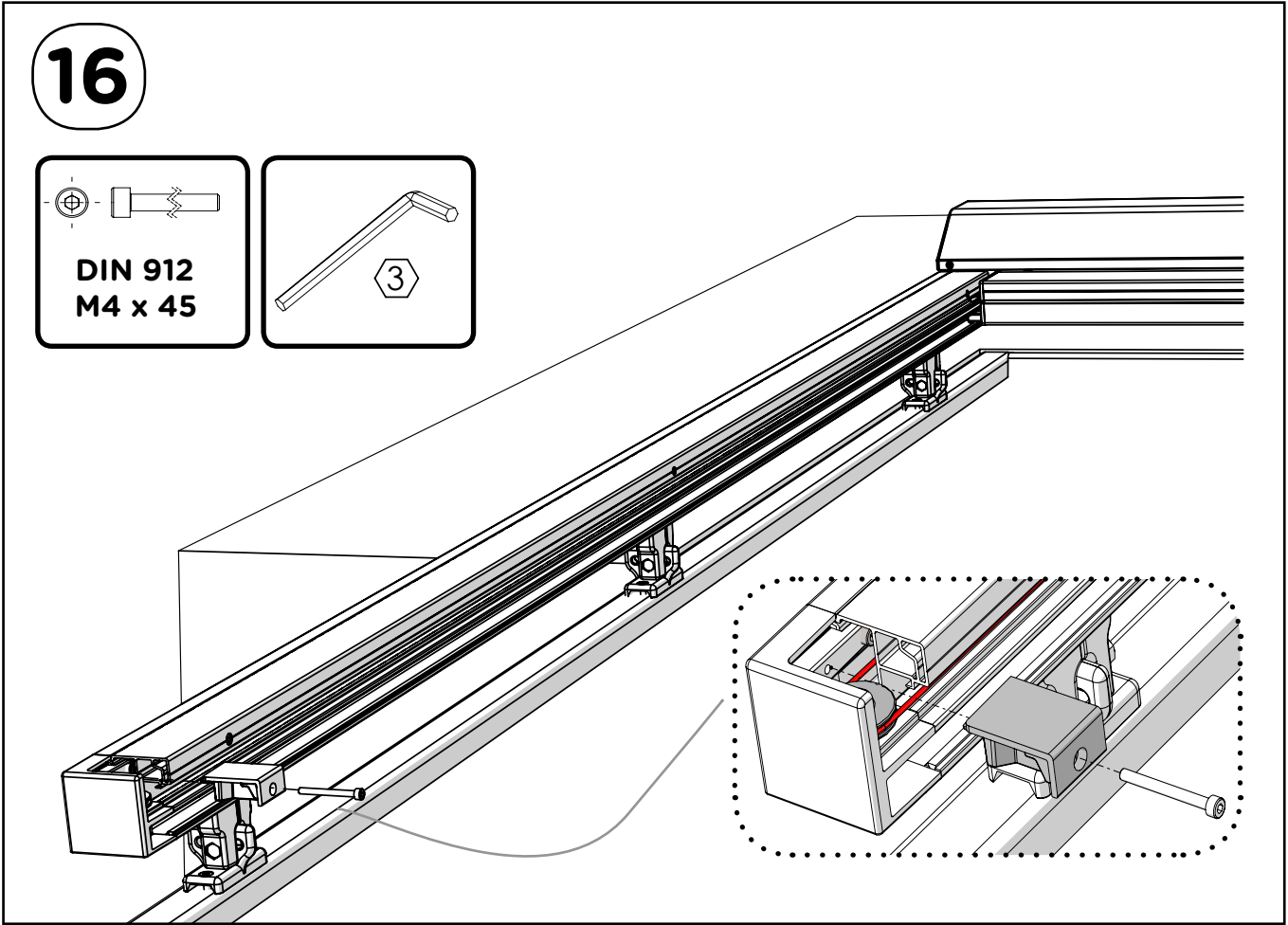
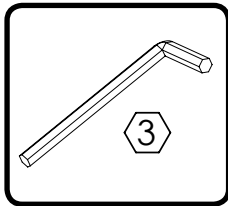
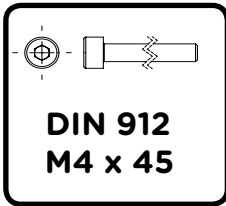

SERIEKOPPLAD - COUPLE - LINKED - GEKOPPELT

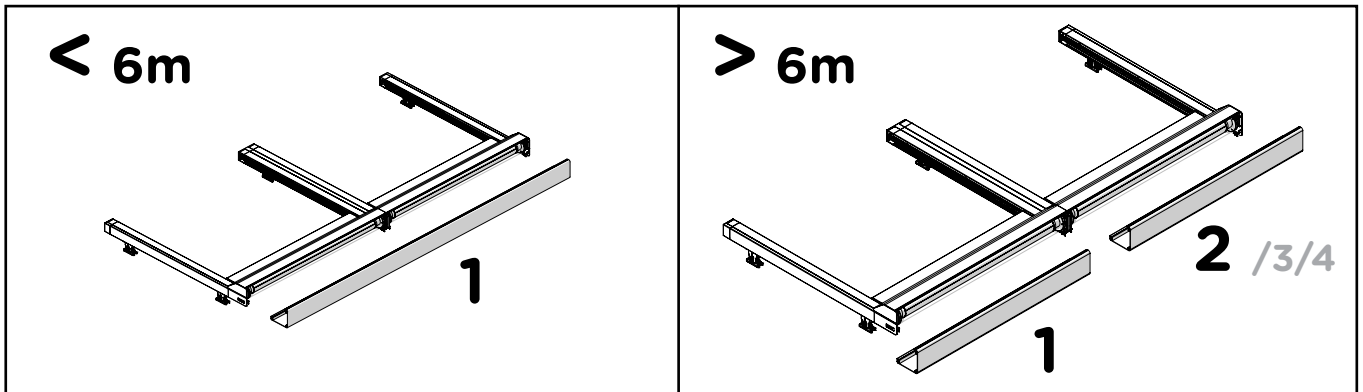
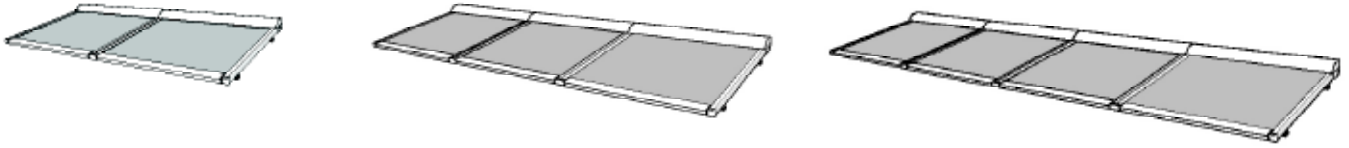

+ *extra montage steg*
étapes de montage supplémentaires
extra mounting steps
extra Montageschritte

1 *se sid.5*
voir p.5
see p.5
sehen p.5

2 *se sid.7*
voir p.7
see p.7
sehen p.7

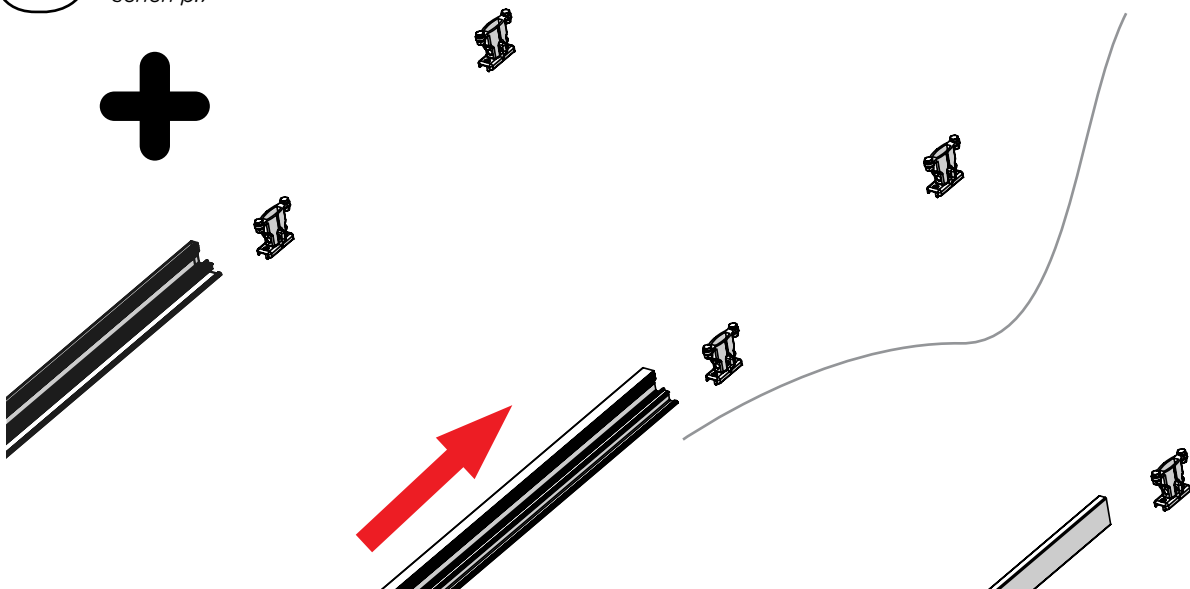
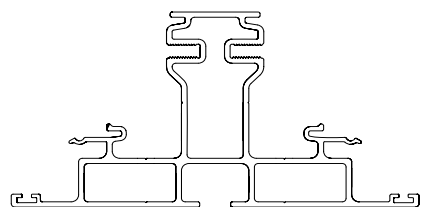

3 se sid.8
voir p.8
see p.8
sehen p.8

+ > 6m

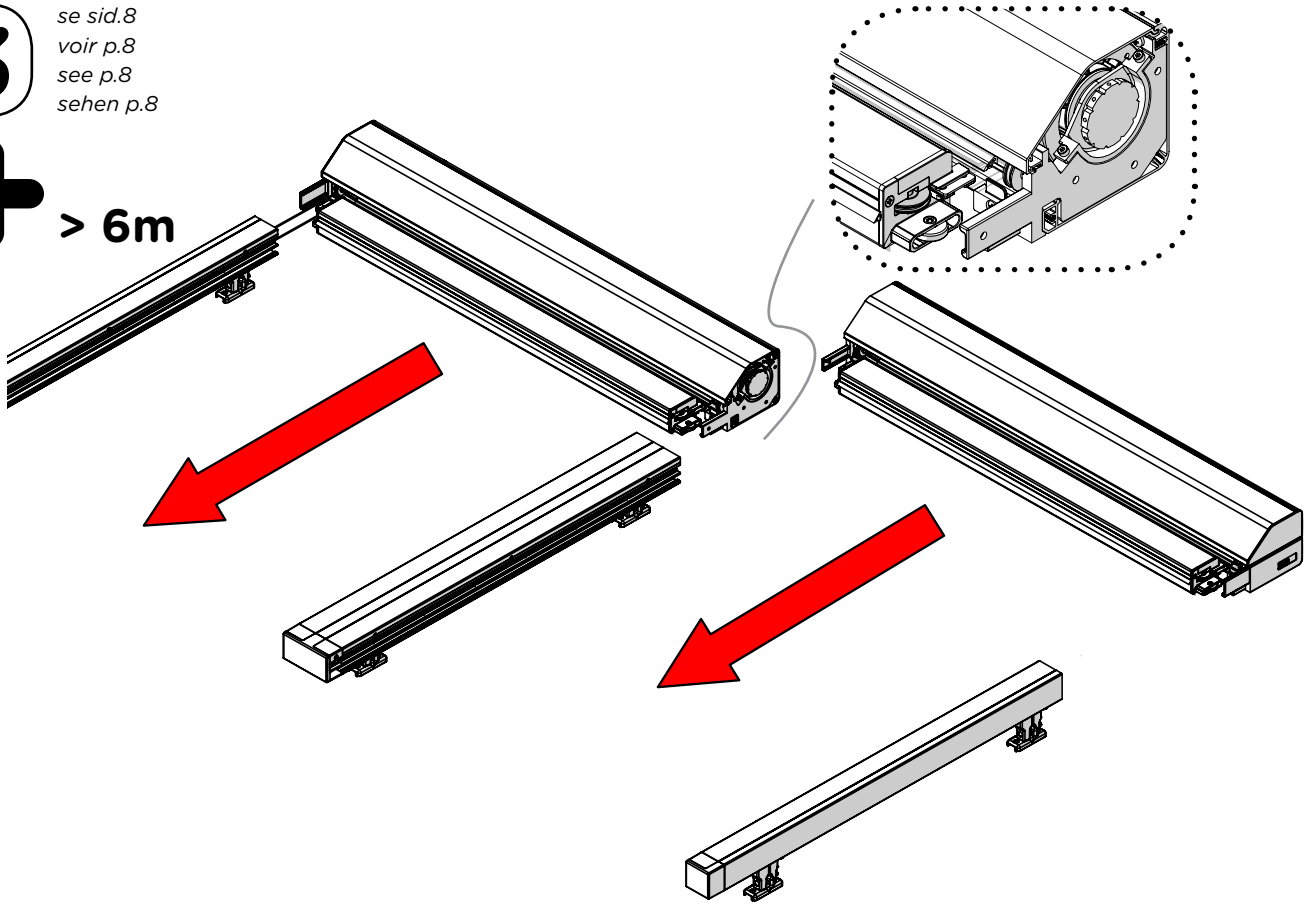

4 **5**

6 se sid.9
voir p.9
see p.9
sehen p.9

+ > 6m

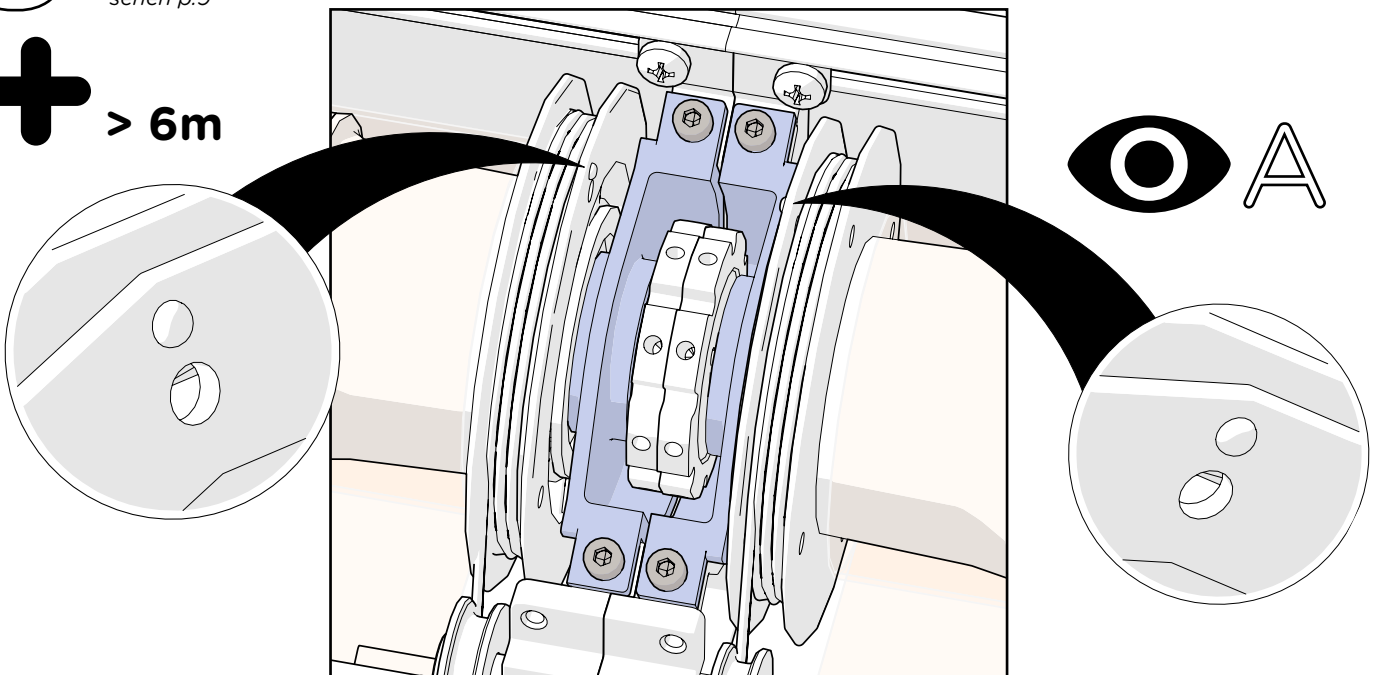

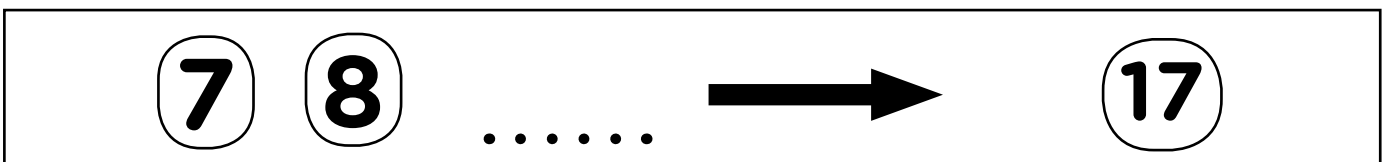
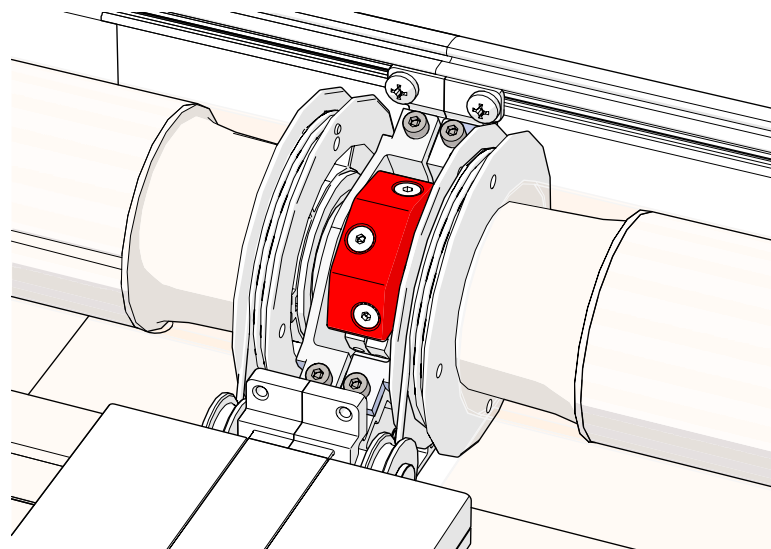
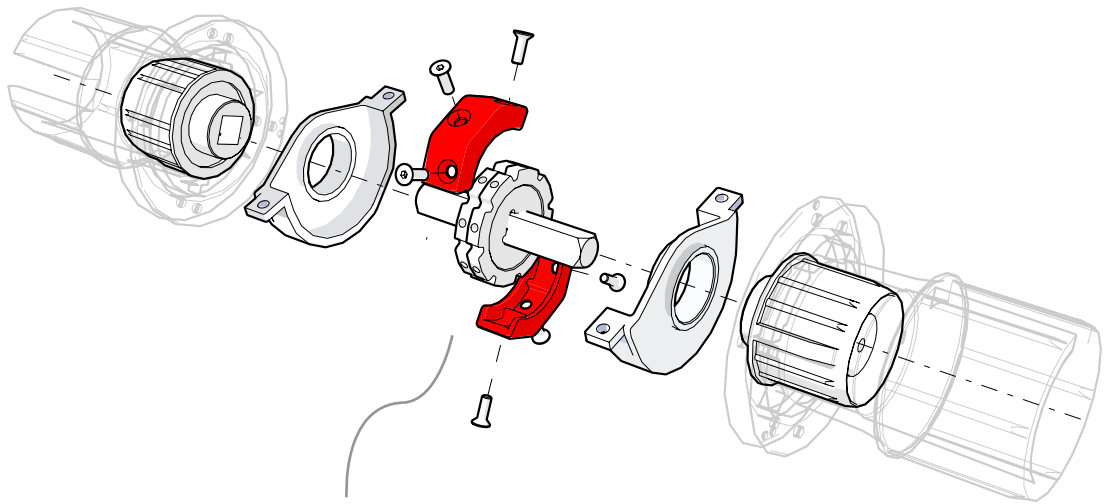
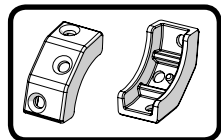
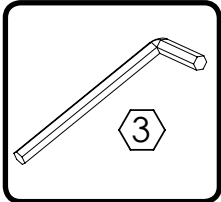
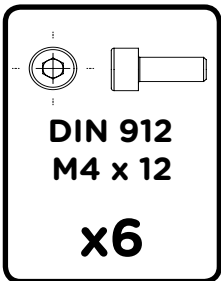
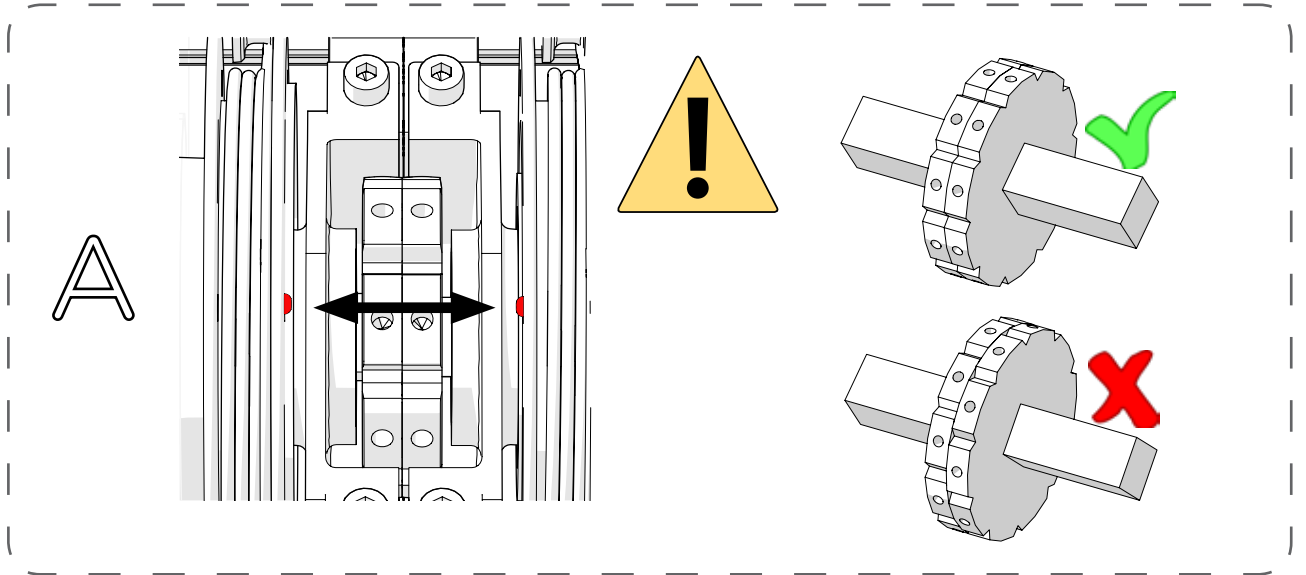

MT 7 - 10

